

REVISIONS		
DATE	NAME	NO.
2-23-2018	CHARLES E. ADAMSON	42627
2-10-2021	CHARLES E. ADAMSON	42627

**NOTE:**  
THIS SHEET HAS BEEN DRAWN USING COMPUTER AIDED DRAFTING/DESIGN (CAD/D) AND COORDINATE GEOMETRY (COGO).

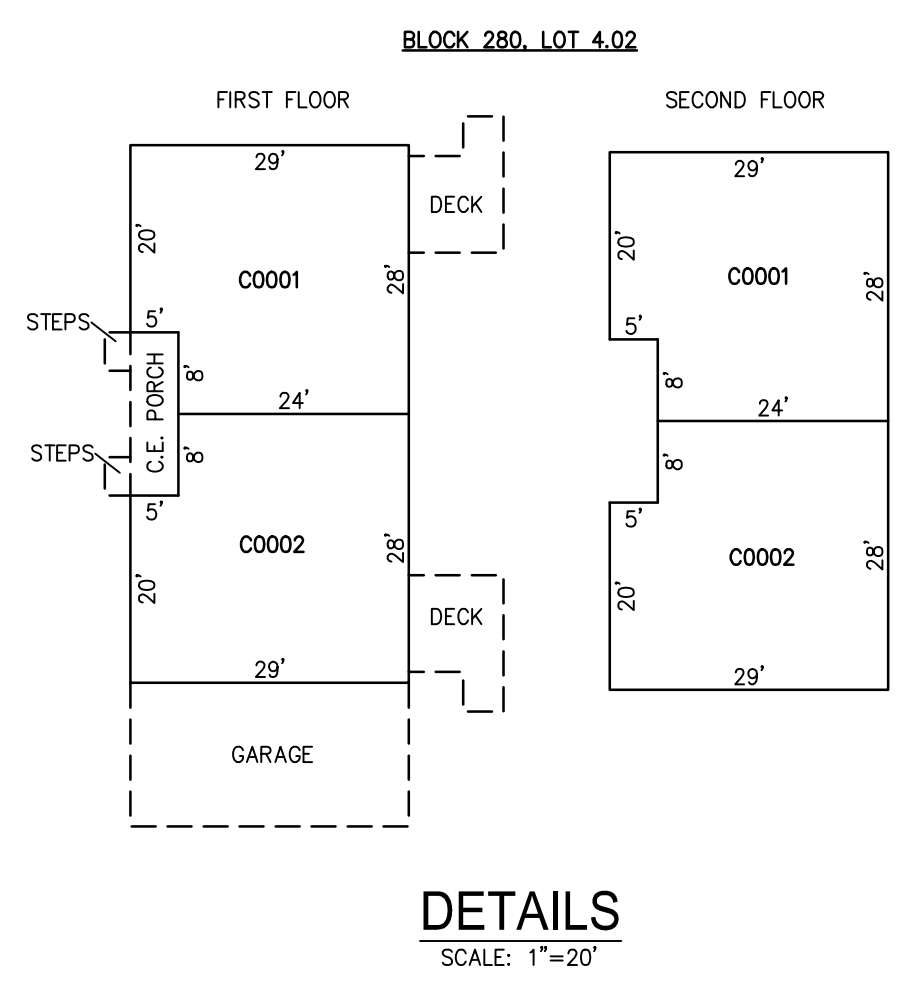
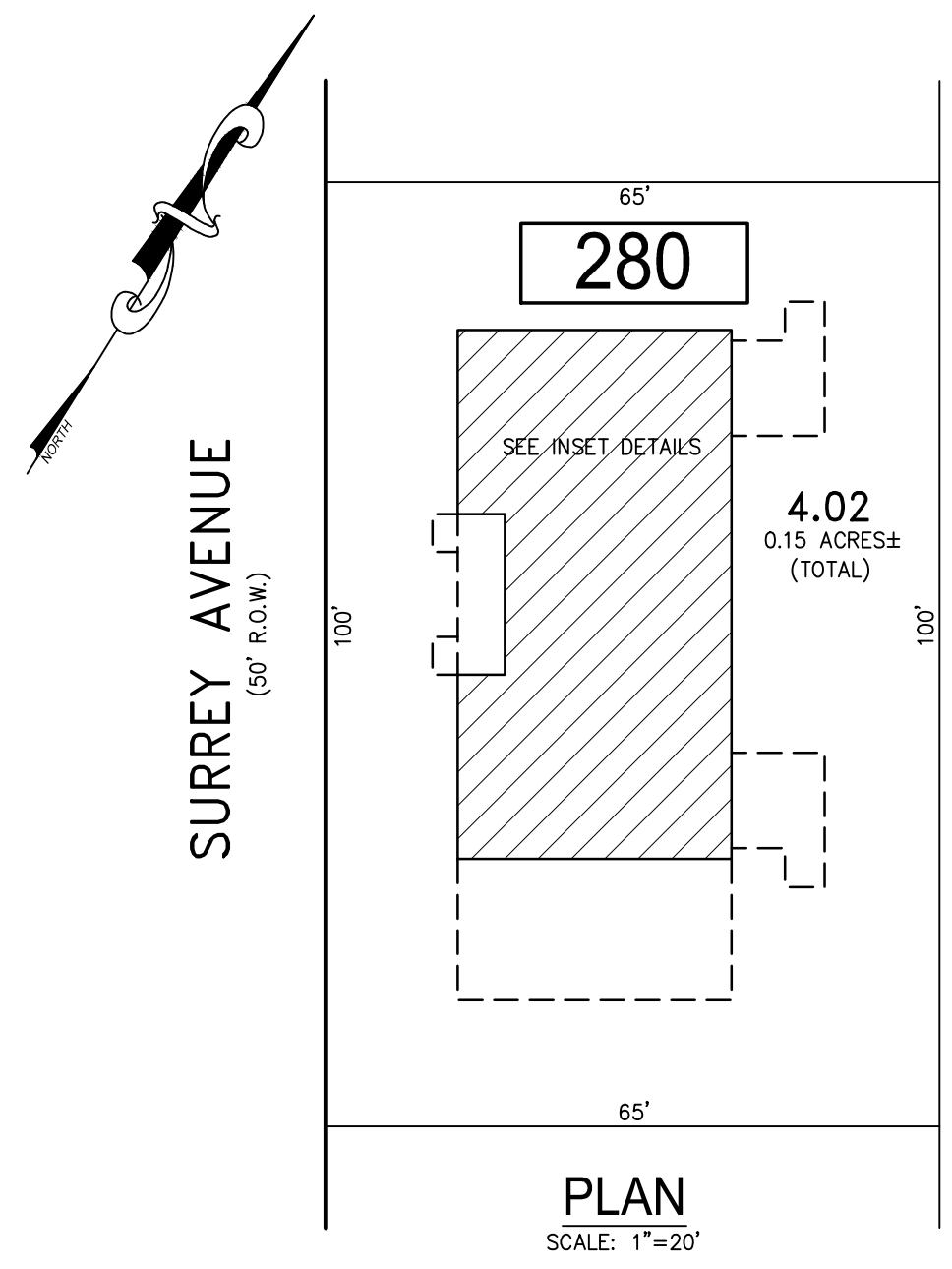

CONDO QUALIFIER	SQUARE FOOTAGE
C0001	1574 SF.
C0002	1574 SF.

BLOCK 280, LOT 4.02  
509 N. SURREY AVENUE CONDOMINIUM

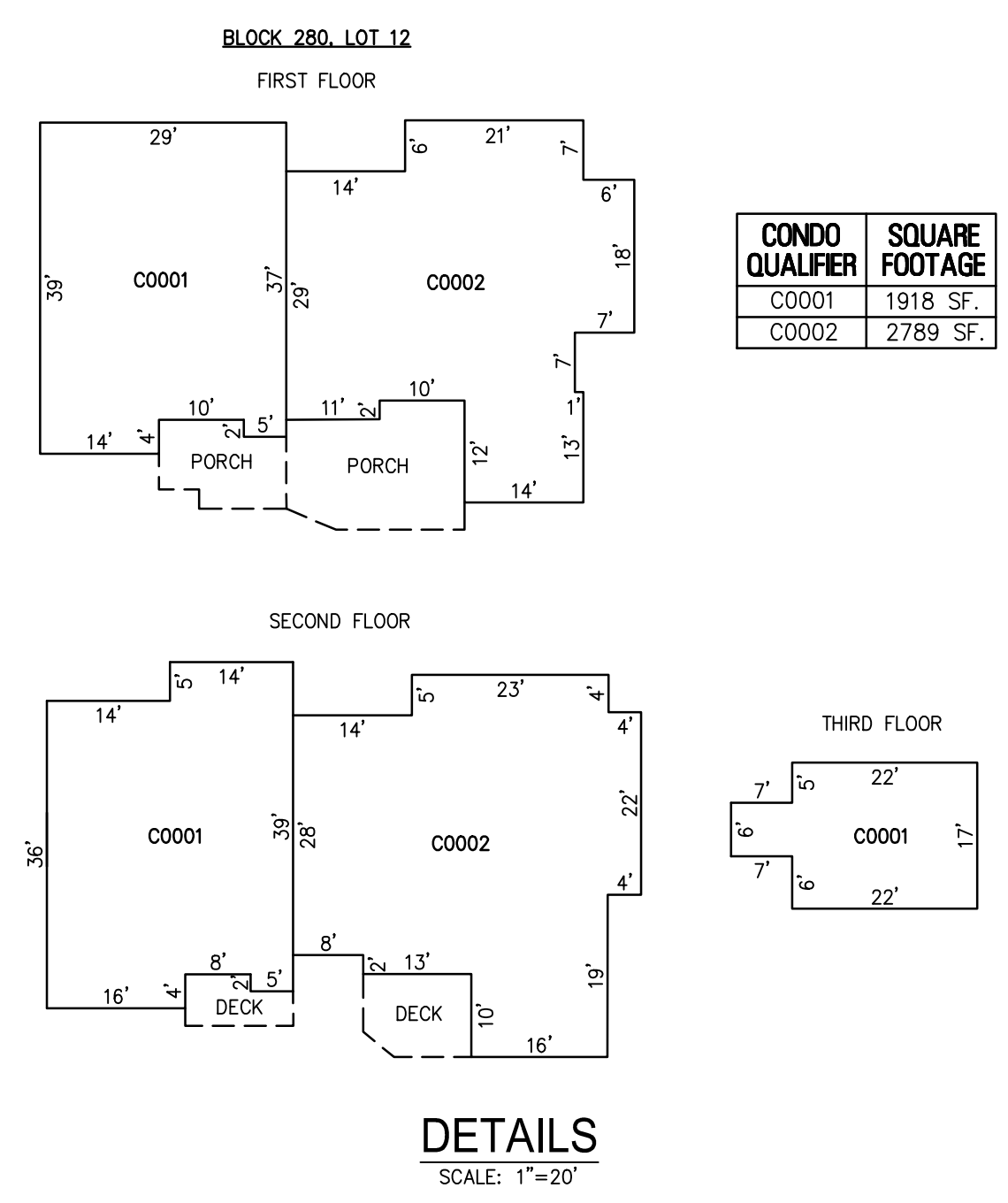
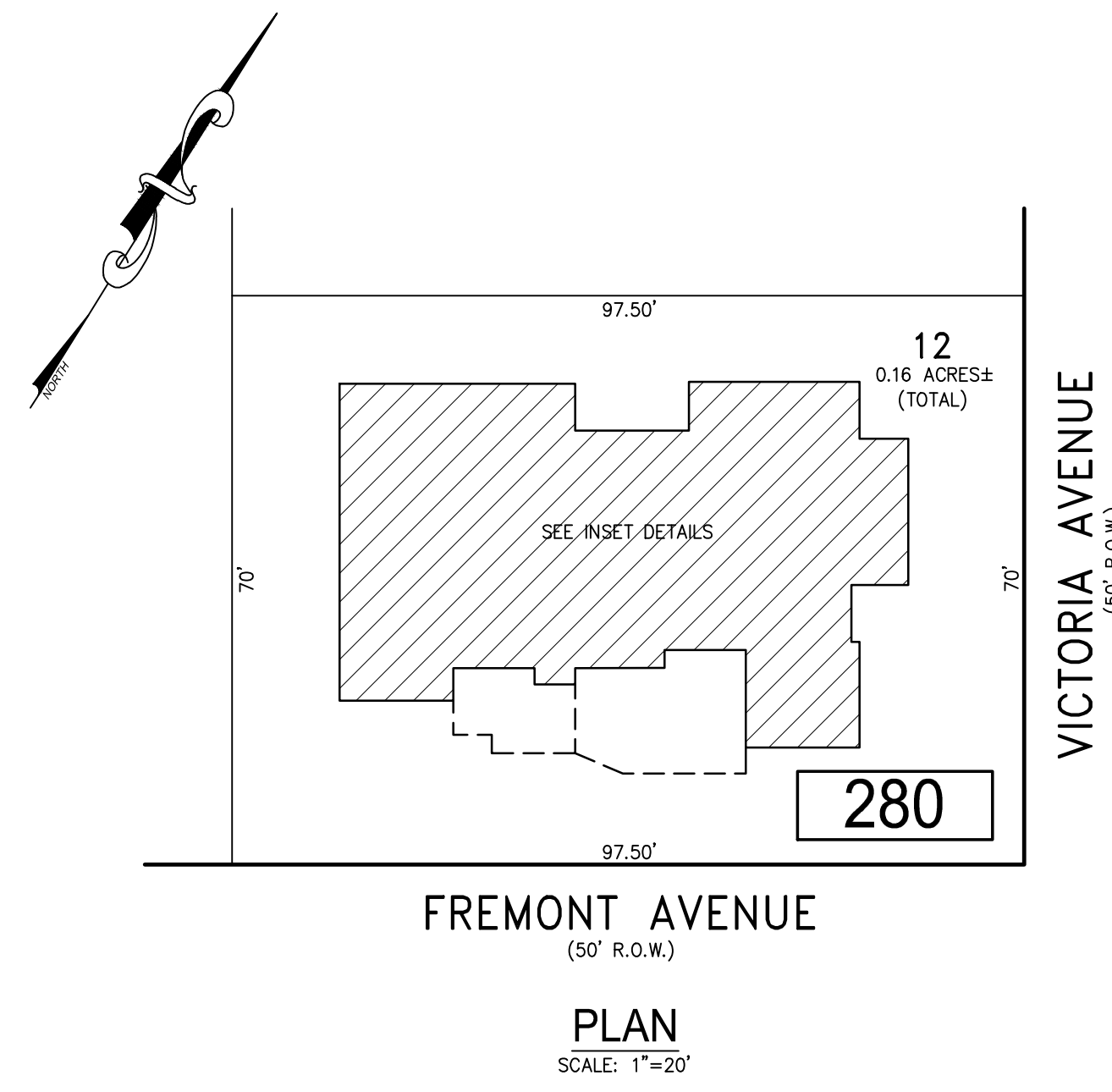

CONDO QUALIFIER	SQUARE FOOTAGE
C0001	1918 SF.
C0002	2789 SF.

BLOCK 280, LOT 12  
502 N. VICTORIA AVENUE CONDOMINIUM

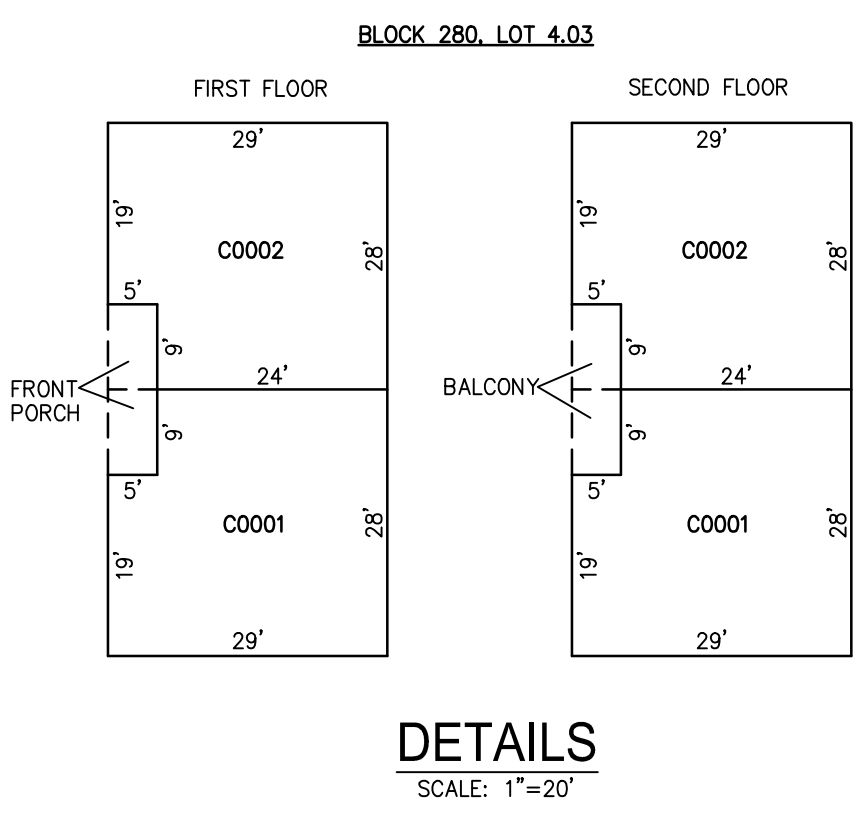
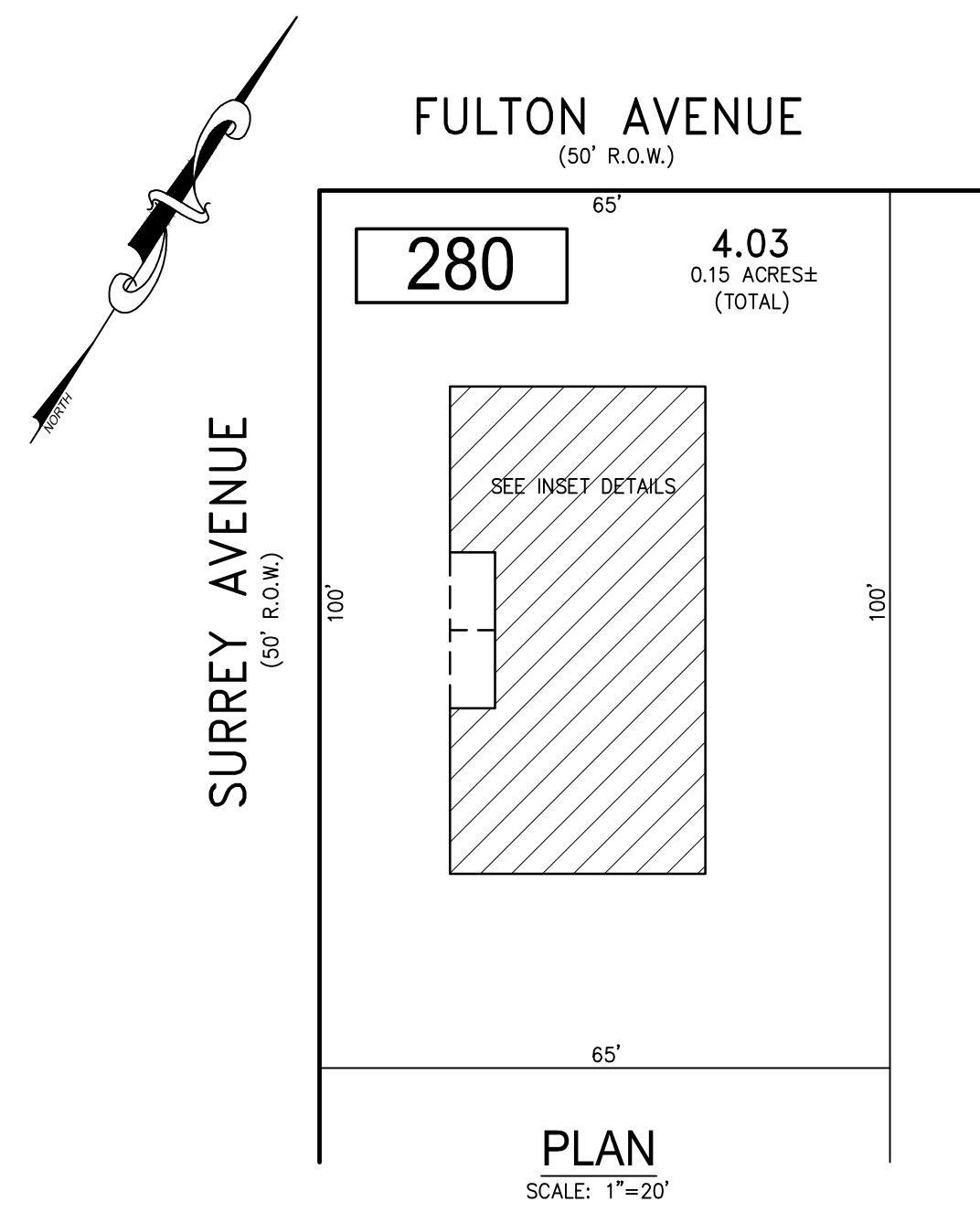

CONDO QUALIFIER	SQUARE FOOTAGE
C0001	1506 SF.
C0002	1506 SF.

BLOCK 280, LOT 4.03  
511-513 N. SURREY AVENUE CONDOMINIUM

BLOCK 279, LOT 1.01  
BLOCK 280, LOT 4.02  
BLOCK 280, LOT 4.03  
BLOCK 280, LOT 12  
SEE SHEET 46

"THIS TAX MAP SHEET HAS BEEN DIGITALLY REVISED USING COMPUTER-AIDED DRAFTING/DESIGN (CADD) & COORDINATE GEOMETRY (COGO). IT IS BASED ON THE ORIGINAL DIGITALLY DRAWN TAX MAP PLATE BEARING THE OFFICIAL NEW JERSEY DIVISION TAXATION APPROVAL STAMP WITH APPROVAL DATE JULY, 20, 2016. SERIAL NUMBER 1070 AND SIGNATURE OF JUDY P. MILLER, CTA, CHIEF PROPERTY ADMINISTRATION AND SHELLY REILLY, CTA, PRINCIPAL FIELD REPRESENTATIVE. THE ORIGINAL DIGITALLY DRAWN TAX MAP PLATE WITH THE OFFICIAL APPROVAL STAMP IS ON FILE WITH REMINGTON & VERNICK ENGINEERS."

**TAX MAP**  
**CITY OF VENTNOR**  
ATLANTIC COUNTY NEW JERSEY  
SCALE: NOTED DATE: 2-19-2015

**CHARLES E. ADAMSON** NJ PROFESSIONAL LAND SURVEYOR LIC. NO. 42627

**RV & W** REMINGTON, VERNICK & WALBERG ENGINEERS  
845 N. MAIN STREET, PLEASANTVILLE, NJ 08232  
(609) 645-7100, FAX (609) 645-7076  
WEB SITE ADDRESS: WWW.RVW.COM  
TO SHOW CONDITIONS AS OF 2-03-2023