

REVISIONS		
DATE	NAME	NO.
9-19-2017	CHARLES E. ADAMSON	42627
2-10-2021	CHARLES E. ADAMSON	42627

NOTE:
THIS SHEET HAS BEEN DRAWN USING COMPUTER AIDED DRAFTING/DESIGN (CADD) AND COORDINATE GEOMETRY (COGO).

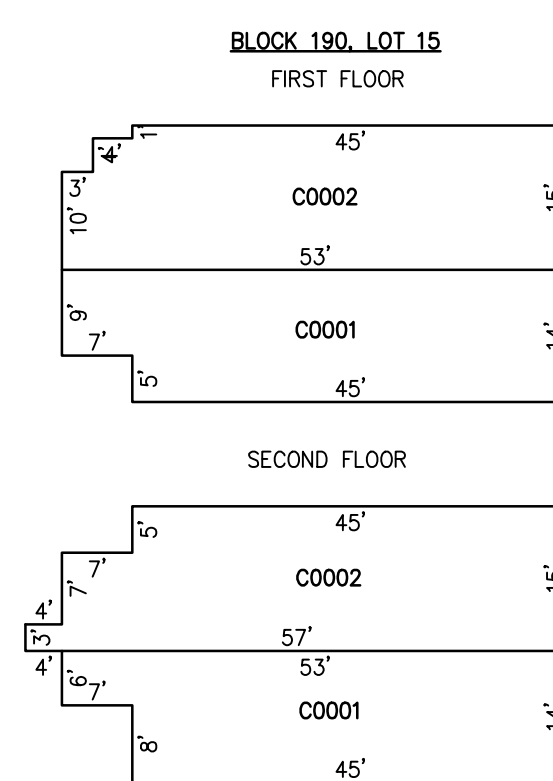
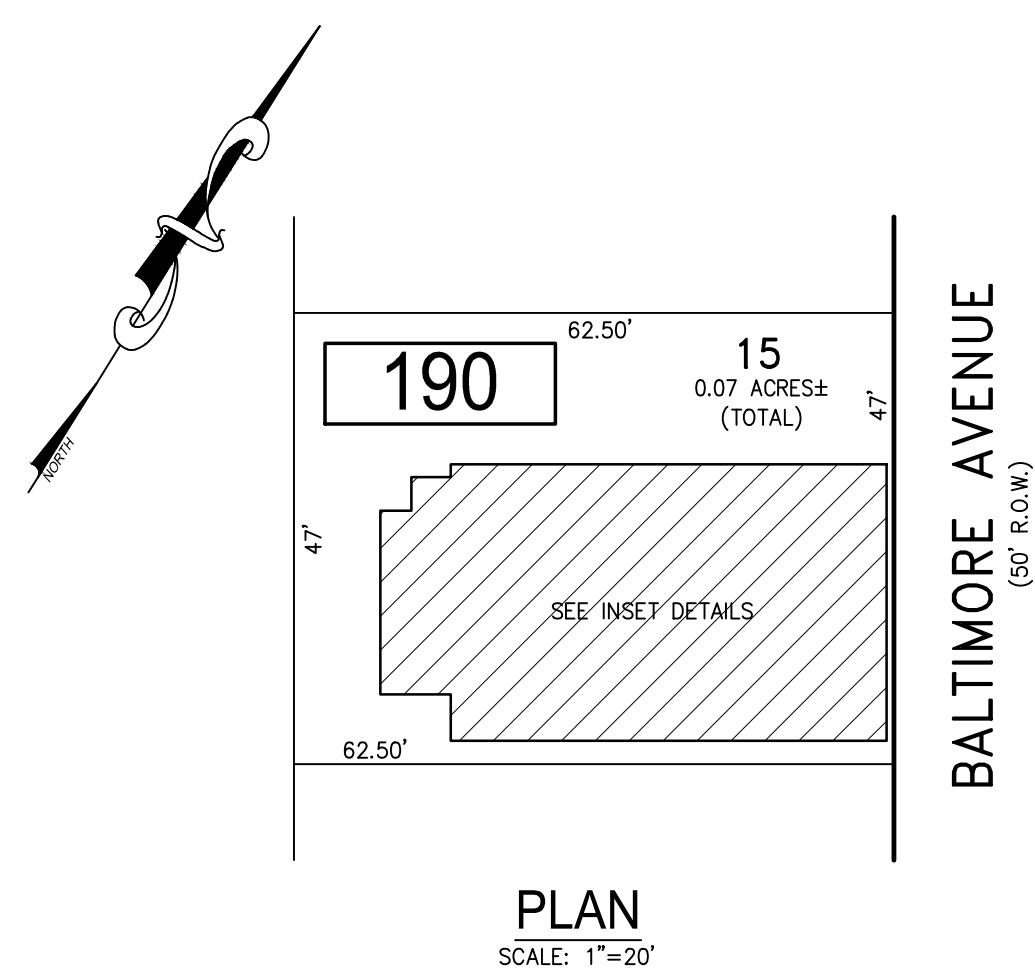

BLOCK 190, LOT 15
116 N. BALTIMORE AVENUE CONDOMINIUM

CONDO QUALIFIER	SQUARE FOOTAGE
C0001	1020 SF.
C0002	1917 SF.

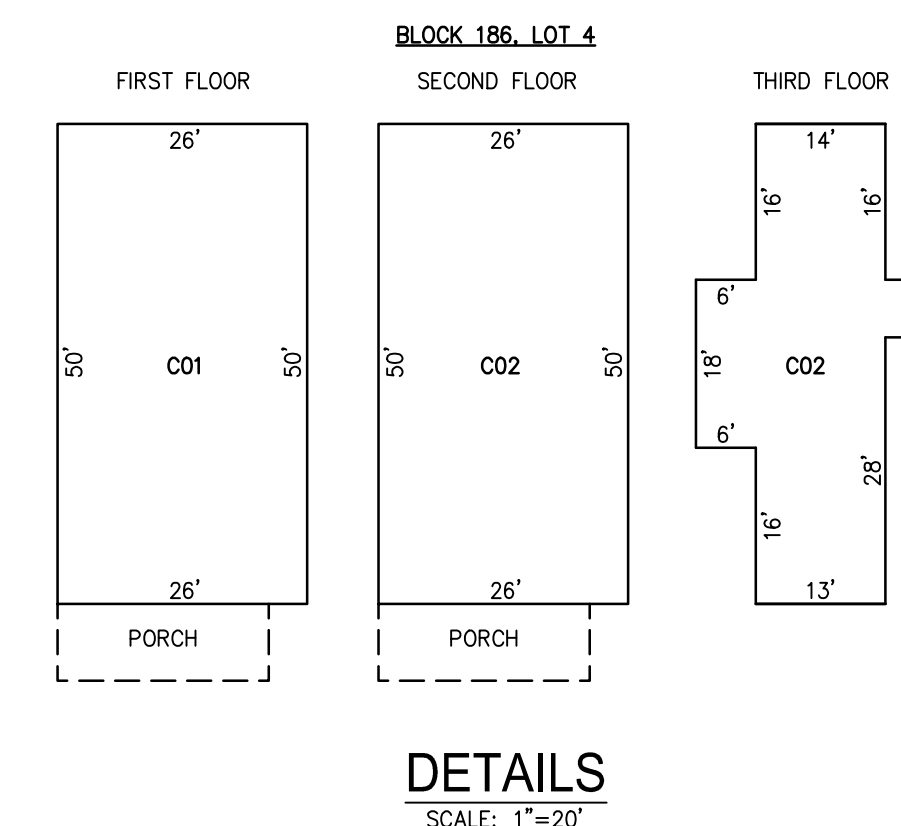
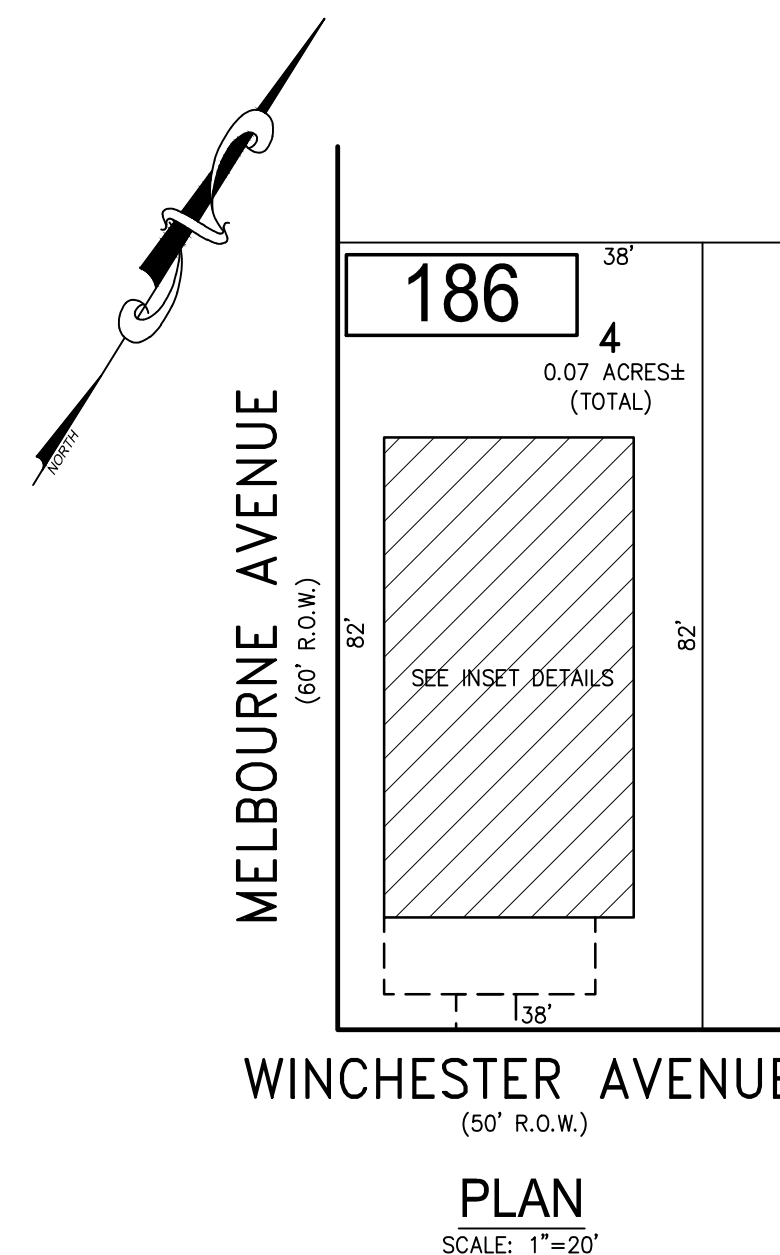

BLOCK 186, LOT 4
7107 WINCHESTER AVENUE CONDOMINIUM

CONDO QUALIFIER	SQUARE FOOTAGE
C01	1451 SF.
C02	1999 SF.

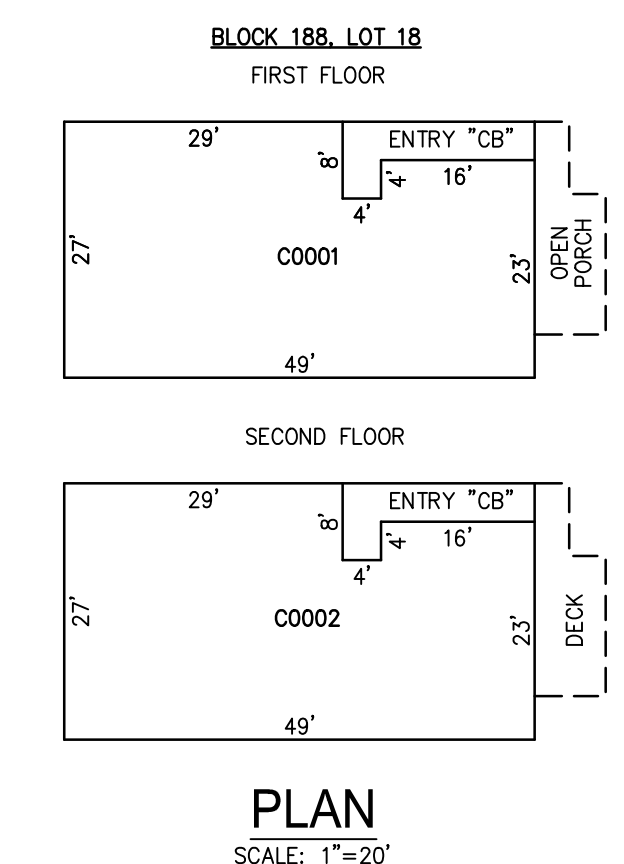
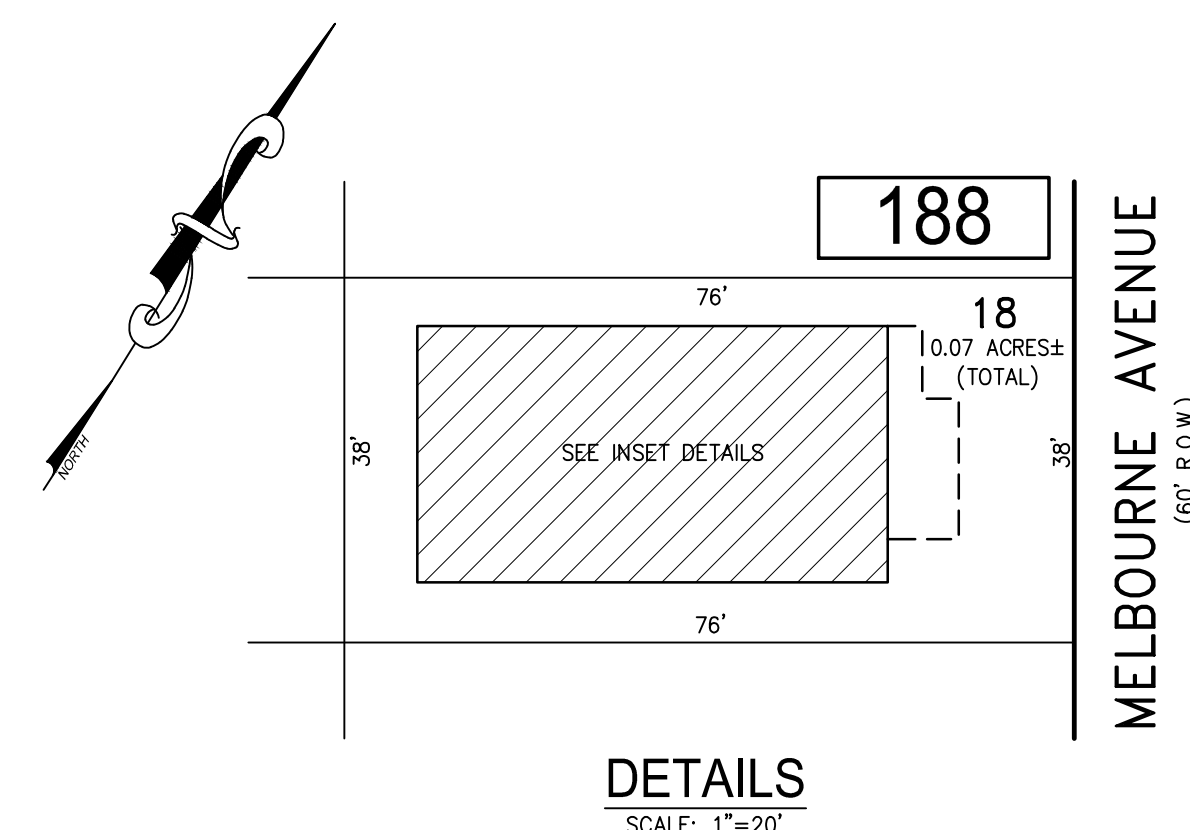

BLOCK 188, LOT 18
118 N. MELBOURNE AVENUE CONDOMINIUM

CONDO QUALIFIER	SQUARE FOOTAGE
C0001	1211 SF.
C0002	1307 SF.

BLOCK 186, LOT 4
BLOCK 188, LOT 18
BLOCK 190, LOT 15
SEE SHEET 31

"THIS TAX MAP SHEET HAS BEEN DIGITALLY REVISED USING COMPUTER-AIDED DRAFTING/DESIGN (CADD) & COORDINATE GEOMETRY (COGO). IT IS BASED ON THE ORIGINAL DIGITALLY DRAWN TAX MAP PLATE BEARING THE OFFICIAL NEW JERSEY DIVISION TAXATION APPROVAL STAMP WITH APPROVAL DATE JULY, 20, 2016. SERIAL NUMBER 1070 AND SIGNATURE OF JUDY P. MILLER, CTA, CHIEF PROPERTY ADMINISTRATION AND SHELLY REILLY, CTA, PRINCIPAL FIELD REPRESENTATIVE. THE ORIGINAL DIGITALLY DRAWN TAX MAP PLATE WITH THE OFFICIAL APPROVAL STAMP IS ON FILE WITH REMINGTON & VERNICK ENGINEERS."

TAX MAP
CITY OF VENTNOR
ATLANTIC COUNTY NEW JERSEY
SCALE: NOTED DATE: 2-19-2015

CHARLES E. ADAMSON NJ PROFESSIONAL LAND SURVEYOR LIC. NO. 42627
24 GA 28048700
REMINGTON, VERNICK & WALBERG ENGINEERS
845 N. MAIN STREET, PLEASANTVILLE, NJ 08232
(609) 645-7100, FAX (609) 645-7076
WEB SITE ADDRESS: WWW.RVE.COM
TO SHOW CONDITIONS AS OF 2-10-2021