

REVISIONS		
DATE	NAME	NO.
1-21-2019	CHARLES E. ADAMSON	42627

NOTE:
THIS SHEET HAS BEEN DRAWN USING COMPUTER AIDED DRAFTING/DESIGN (CADD) AND COORDINATE GEOMETRY (COGO).

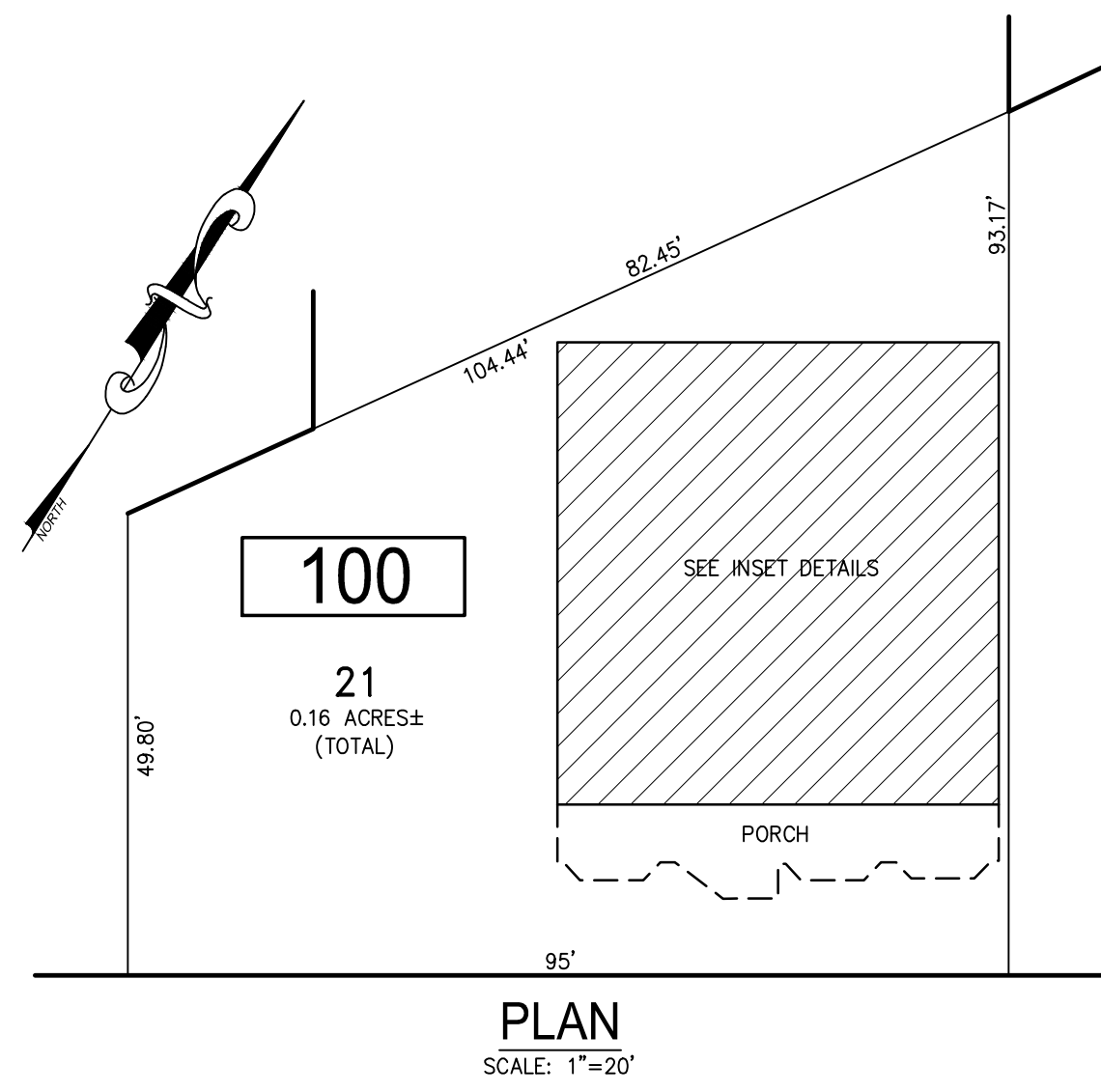

BLOCK 100, LOT 21
5207 WINCHESTER AVENUE CONDOMINIUM

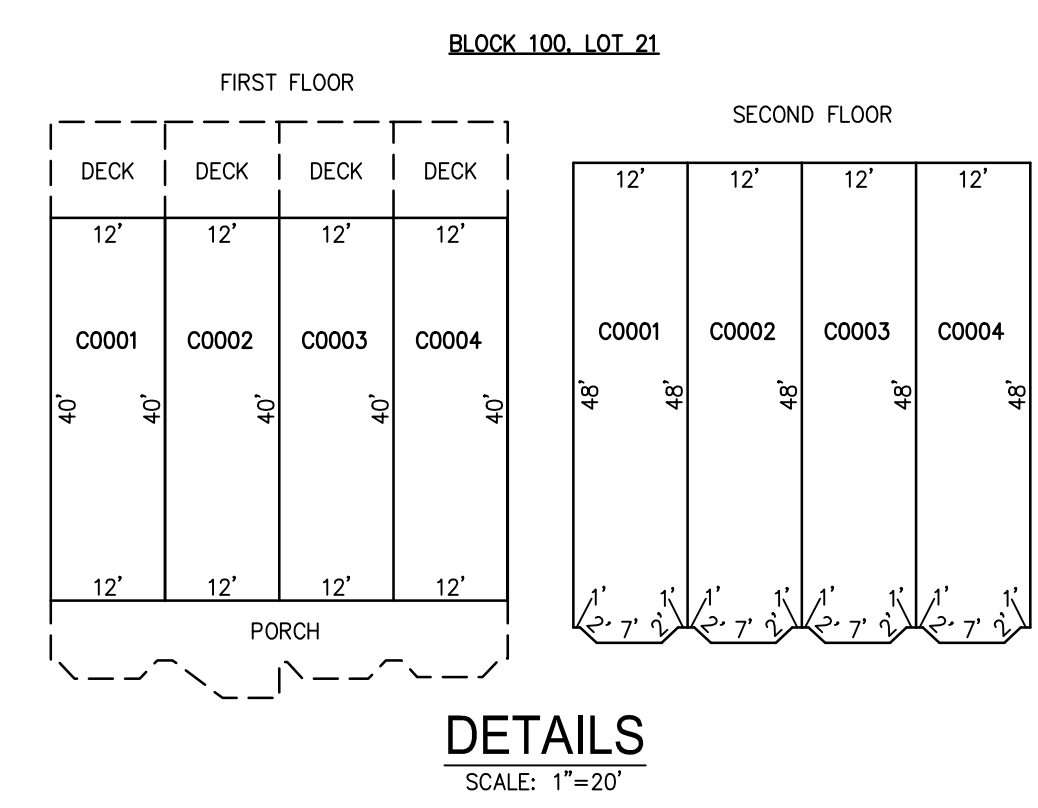

CONDO QUALIFIER	SQUARE FOOTAGE
C0001	1219 SF.
C0002	1219 SF.
C0003	1219 SF.
C0004	1219 SF.

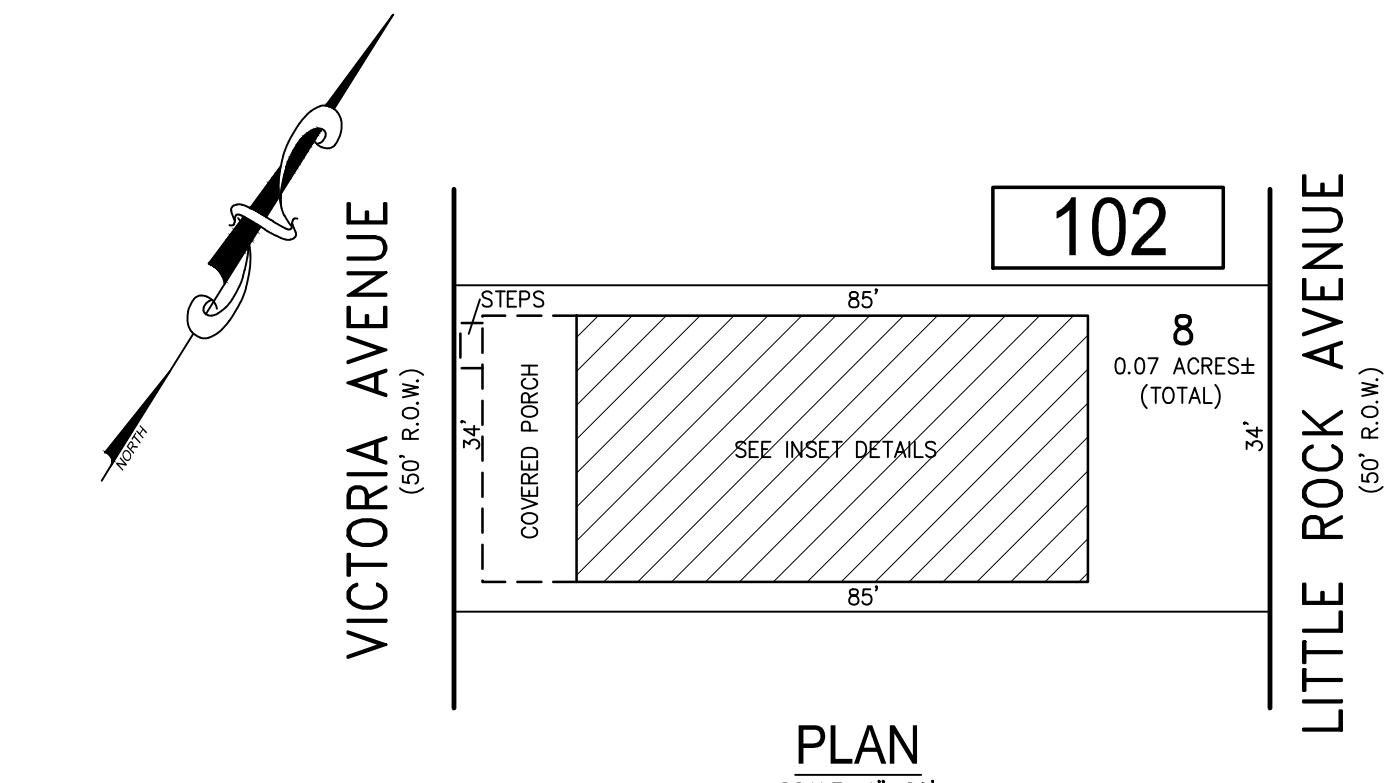

BLOCK 102, LOT 8
VICTORIA AVENUE CONDOMINIUM
13-15 NORTH VICTORIA AVENUE

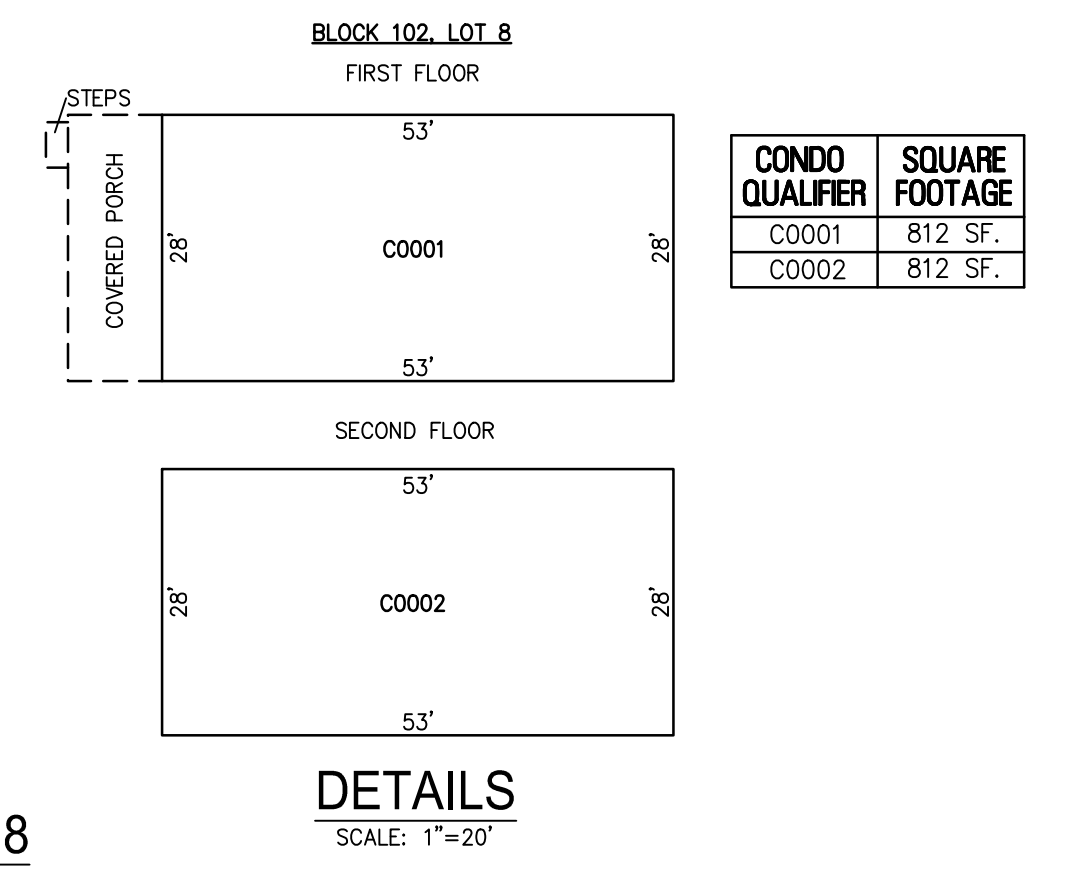

CONDO QUALIFIER	SQUARE FOOTAGE
C0001	812 SF.
C0002	812 SF.

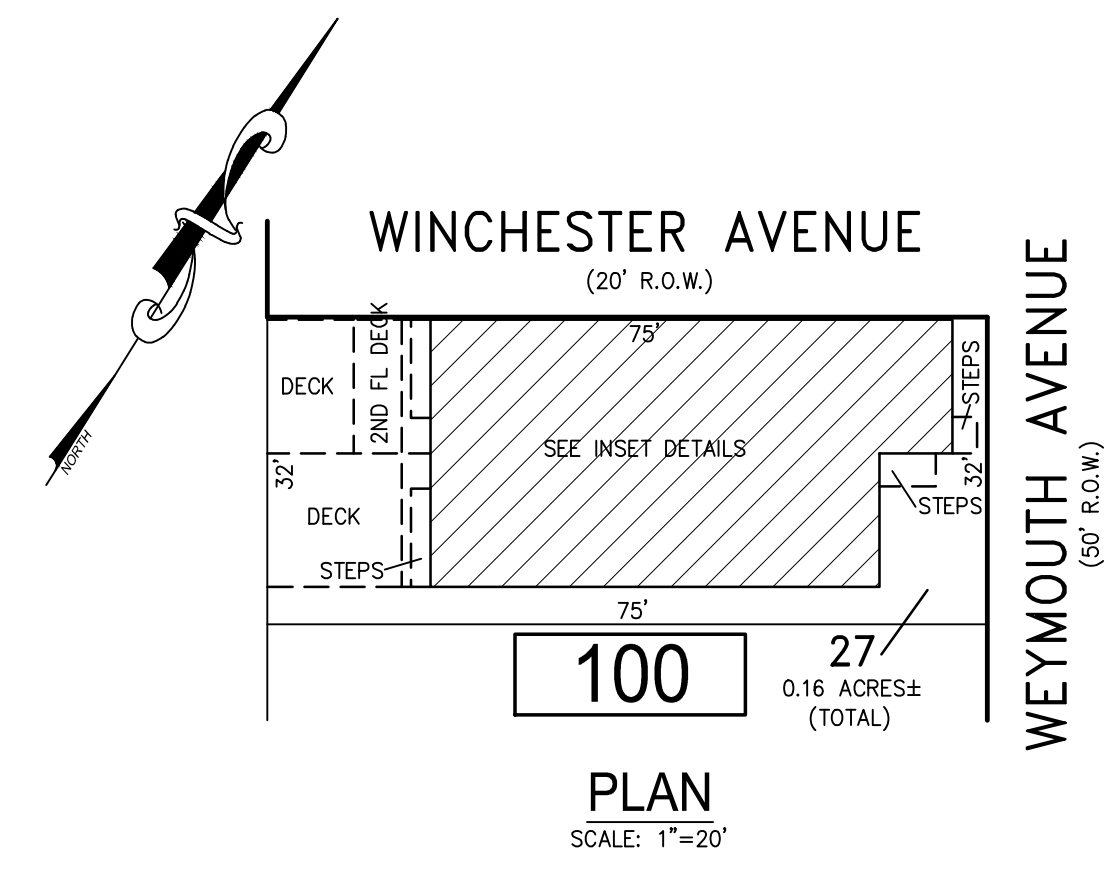

BLOCK 100, LOT 27
36 N WEYMOUTH AVENUE CONDOMINIUM

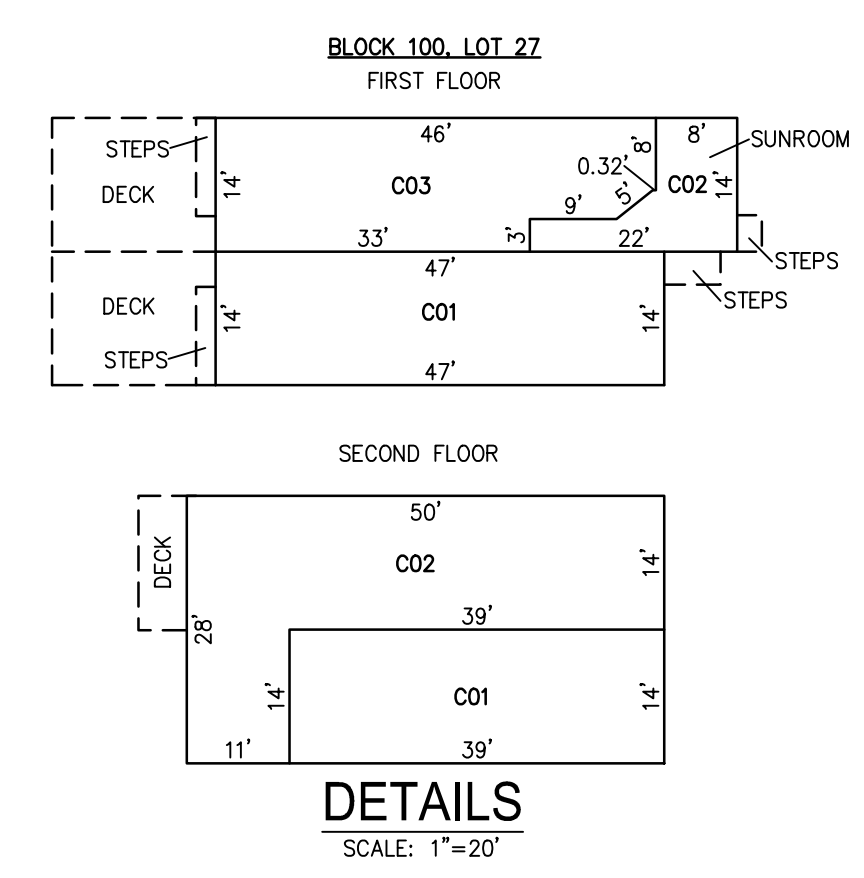

CONDO QUALIFIER	SQUARE FOOTAGE
C01	1180 SF.
C02	1000 SF.
C03	592 SF.

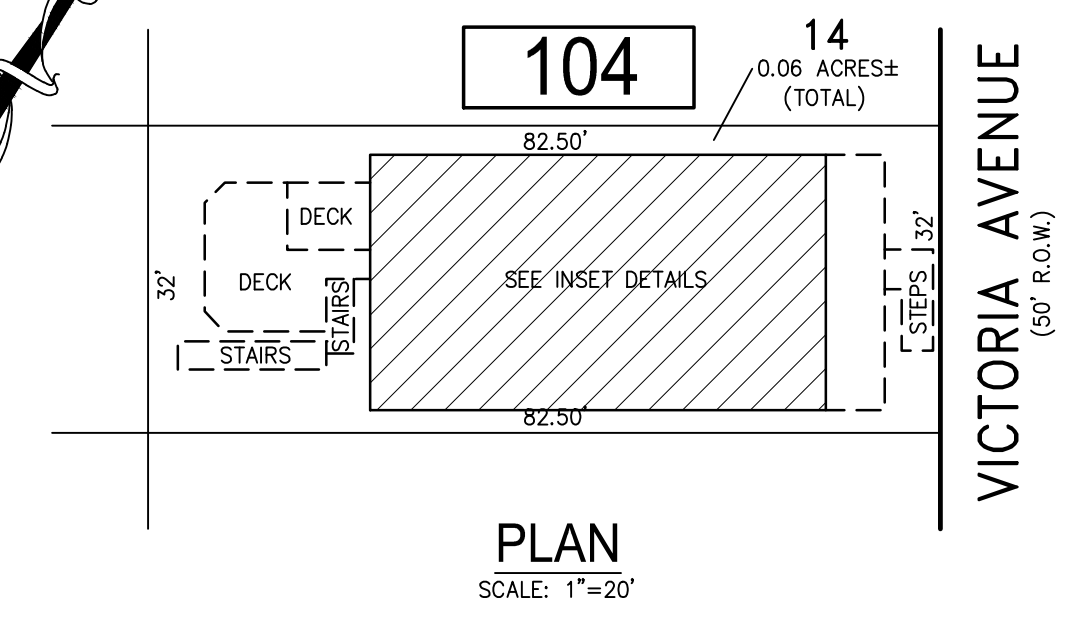

BLOCK 104, LOT 14
10 NORTH VICTORIA AVENUE CONDOMINIUM

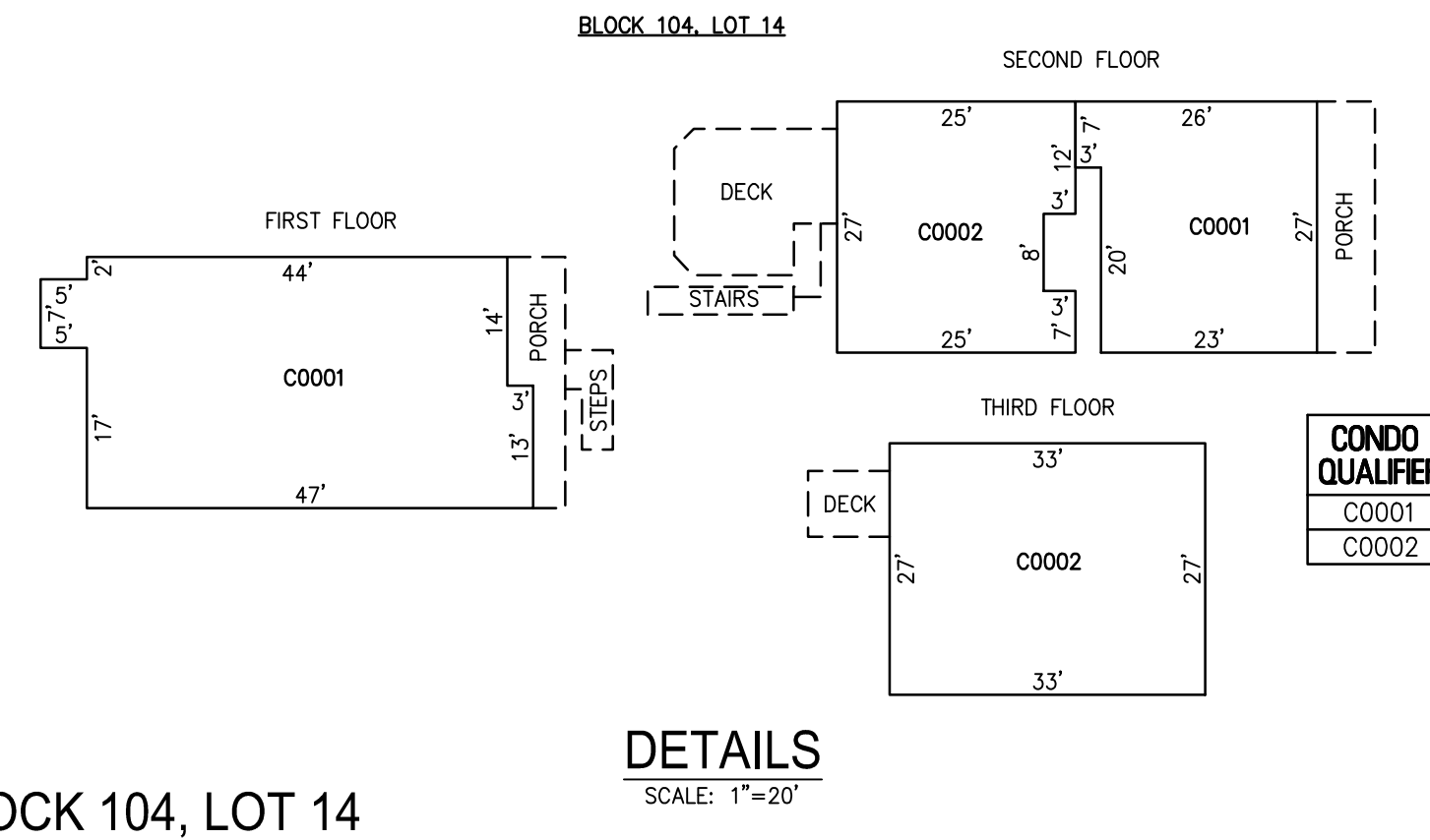

CONDO QUALIFIER	SQUARE FOOTAGE
C0001	1868 SF.
C0002	1352 SF.

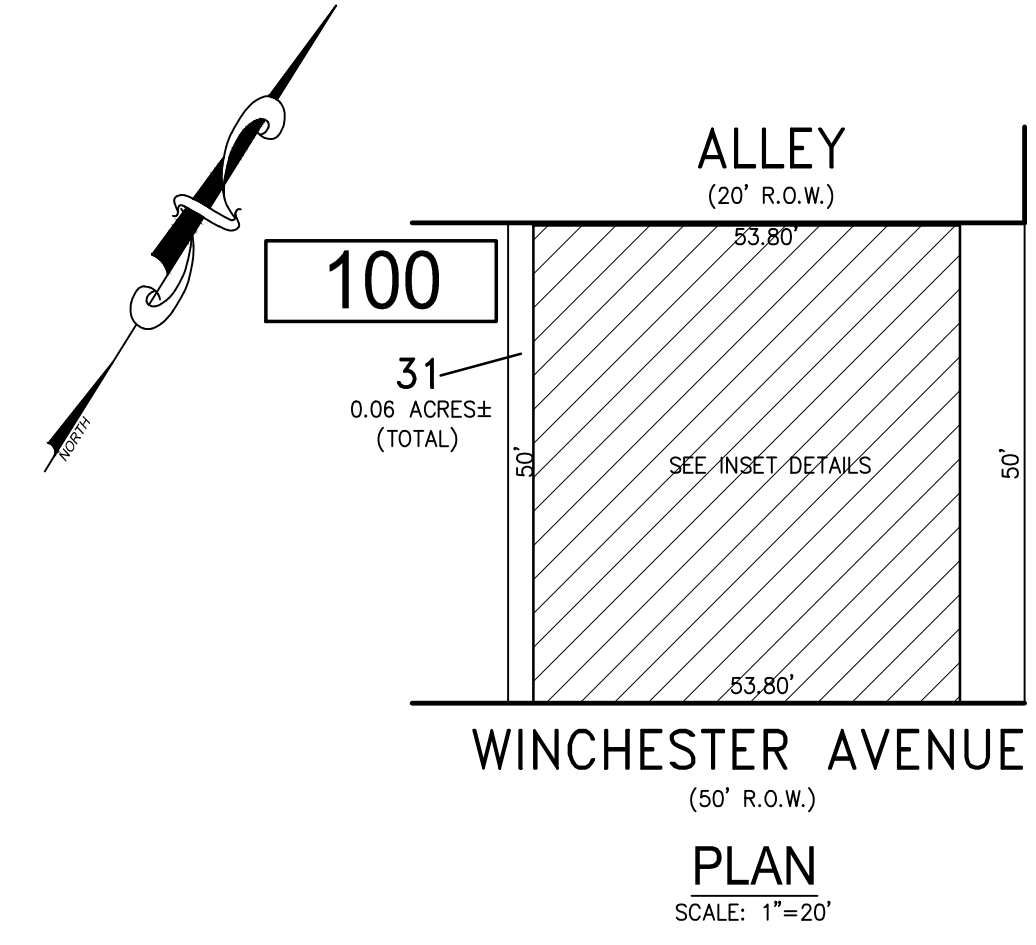

BLOCK 100, LOT 31
5251 WINCHESTER CONDOMINIUM
5251 WINCHESTER AVENUE

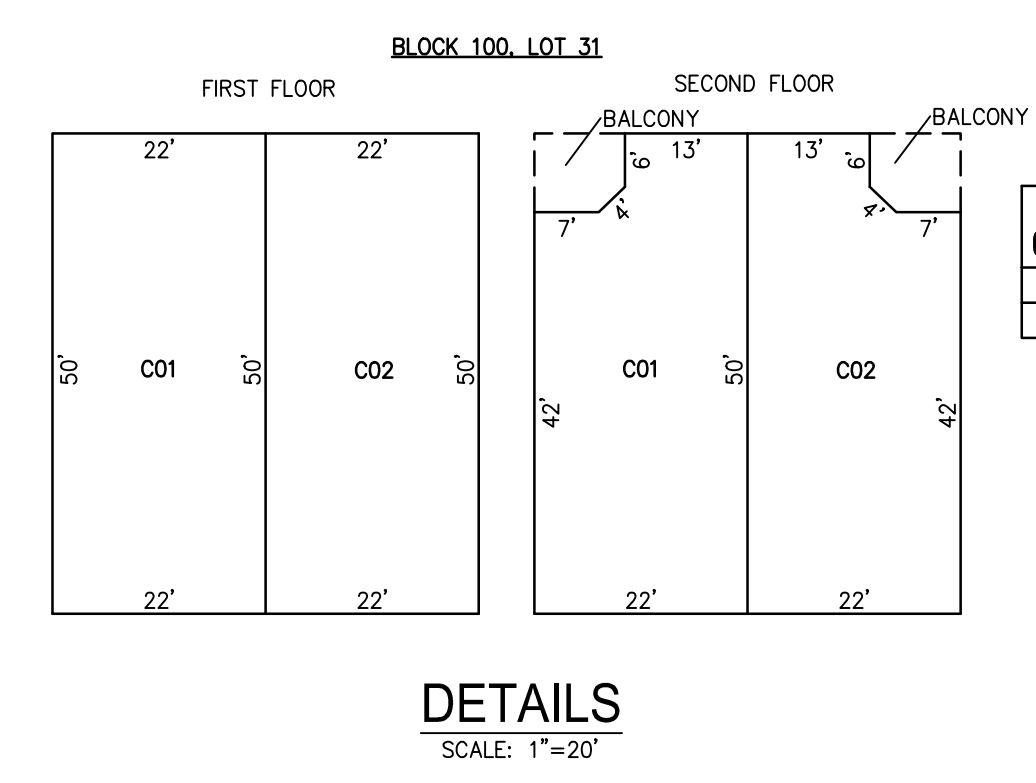

CONDO QUALIFIER	SQUARE FOOTAGE
C01	2112 SF.
C02	2112 SF.

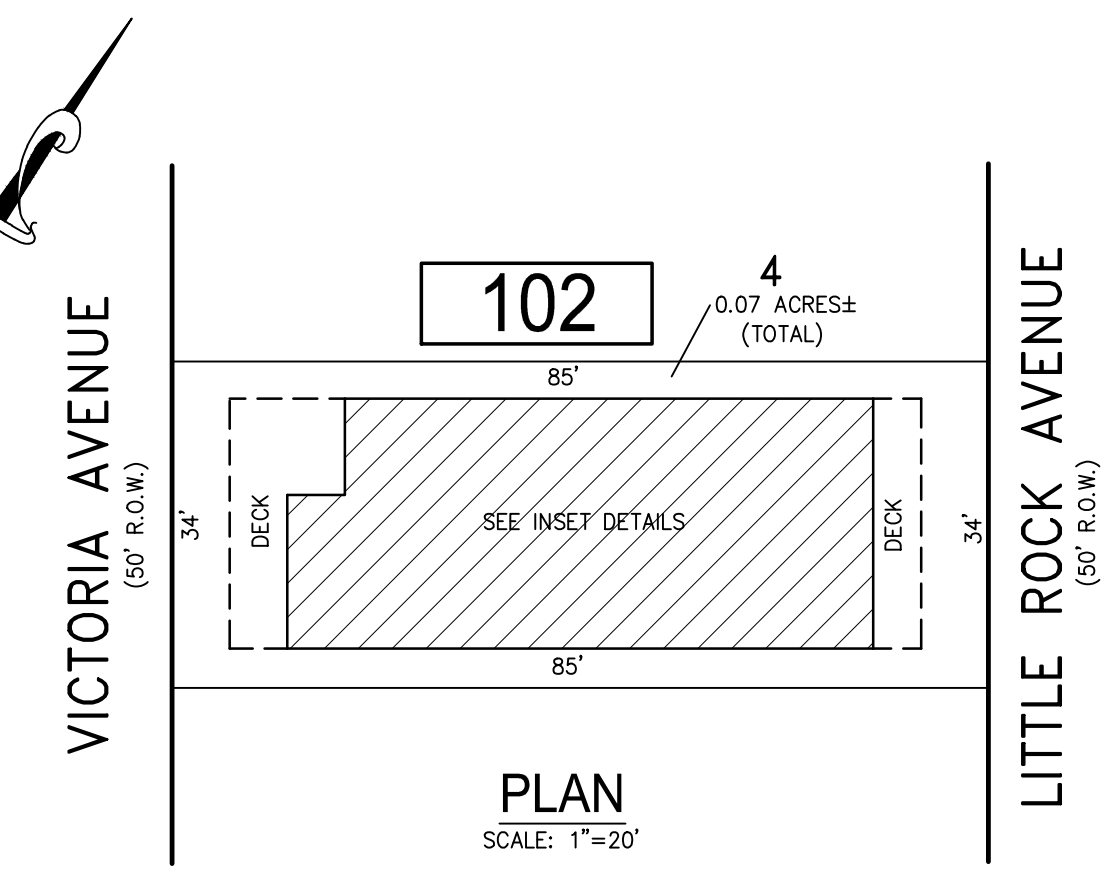

BLOCK 102, LOT 4
3 NORTH VICTORIA AVENUE CONDOMINIUM

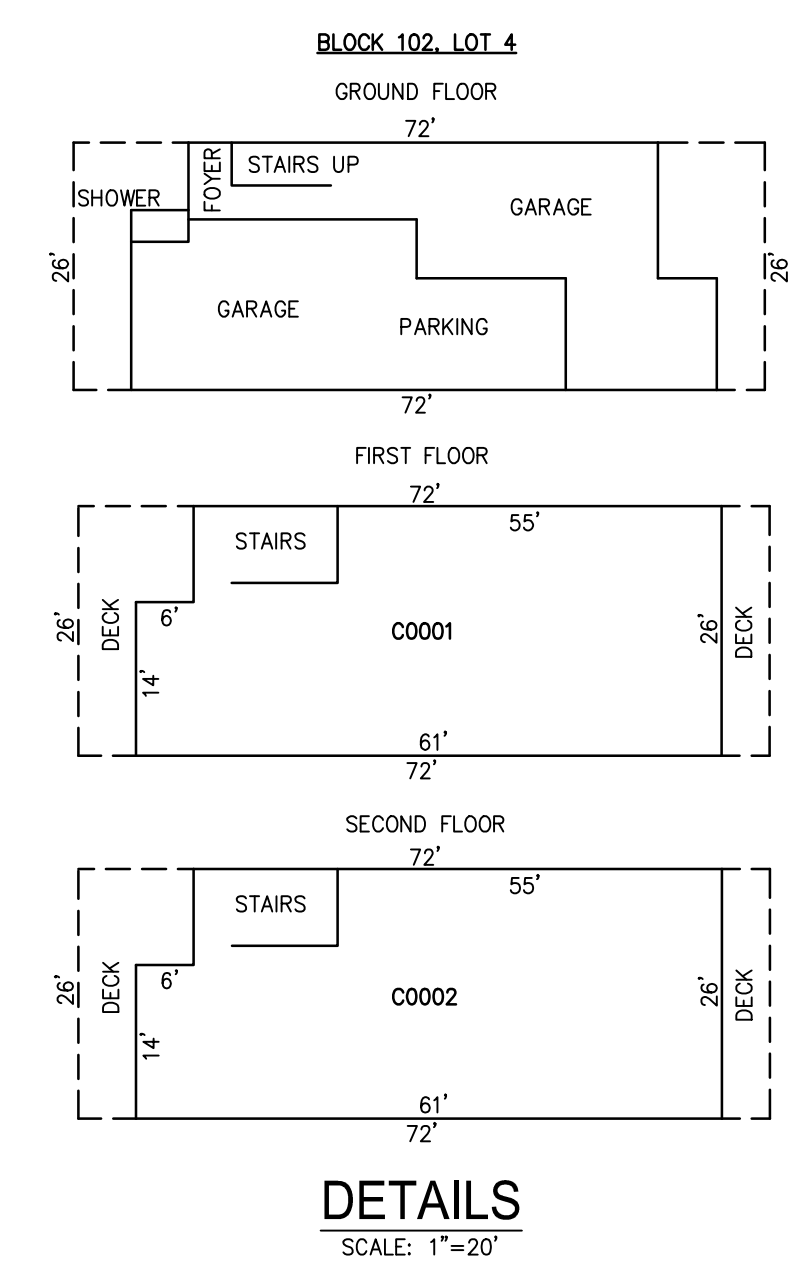

CONDO QUALIFIER	SQUARE FOOTAGE
C0001	1,502 SF.
C0002	1,502 SF.

BLOCK 100, LOT 21
BLOCK 100, LOT 27
BLOCK 100, LOT 31
BLOCK 102, LOT 4
BLOCK 102, LOT 8
BLOCK 104, LOT 14
SEE SHEET 18

"THIS TAX MAP SHEET HAS BEEN DIGITALLY REVISED USING COMPUTER-AIDED DRAFTING/DESIGN (CADD) & COORDINATE GEOMETRY (COGO). IT IS BASED ON THE ORIGINAL DIGITALLY DRAWN TAX MAP PLATE BEARING THE OFFICIAL NEW JERSEY DIVISION TAXATION APPROVAL STAMP WITH APPROVAL DATE JULY, 20, 2016. SERIAL NUMBER 1070 AND SIGNATURE OF JUDY P. MILLER, CTA, CHIEF PROPERTY ADMINISTRATION AND SHELLY REILLY, CTA, PRINCIPAL FIELD REPRESENTATIVE. THE ORIGINAL DIGITALLY DRAWN TAX MAP PLATE WITH THE OFFICIAL APPROVAL STAMP IS ON FILE WITH REMINGTON & VERNICK ENGINEERS."

TAX MAP
CITY OF VENTNOR
ATLANTIC COUNTY NEW JERSEY
SCALE: NOTED DATE: 2-19-2015

CHARLES E. ADAMSON NJ PROFESSIONAL LAND SURVEYOR LIC. NO. 42627

RV & W **REMINGTON, VERNICK & WALBERG ENGINEERS**
845 N. MAIN STREET, PLEASANTVILLE, NJ 08232
(609) 645-7000, FAX (609) 645-7076
WEB SITE ADDRESS: WWW.RVW.COM
TO SHOW CONDITIONS AS OF 3-01-2022