

REVISIONS		
DATE	NAME	NO.
2-10-2021	CHARLES E. ADAMSON	42627

NOTE:
THIS SHEET HAS BEEN DRAWN USING COMPUTER AIDED DRAFTING/DESIGN (CAD/D) AND COORDINATE GEOMETRY (COGO).

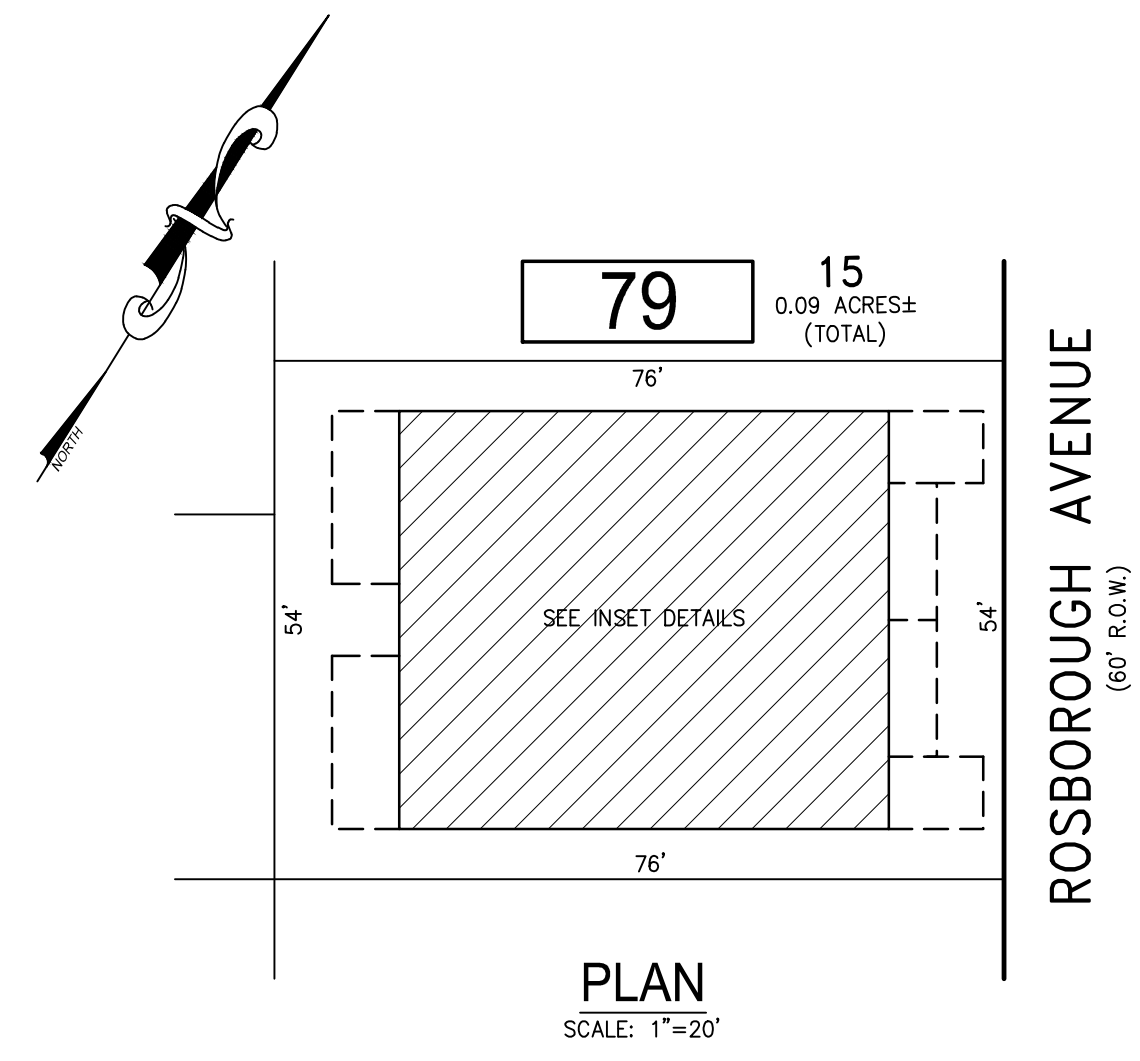

BLOCK 79, LOT 15
6 SOUTH ROSBOROUGH AVENUE CONDOMINIUM

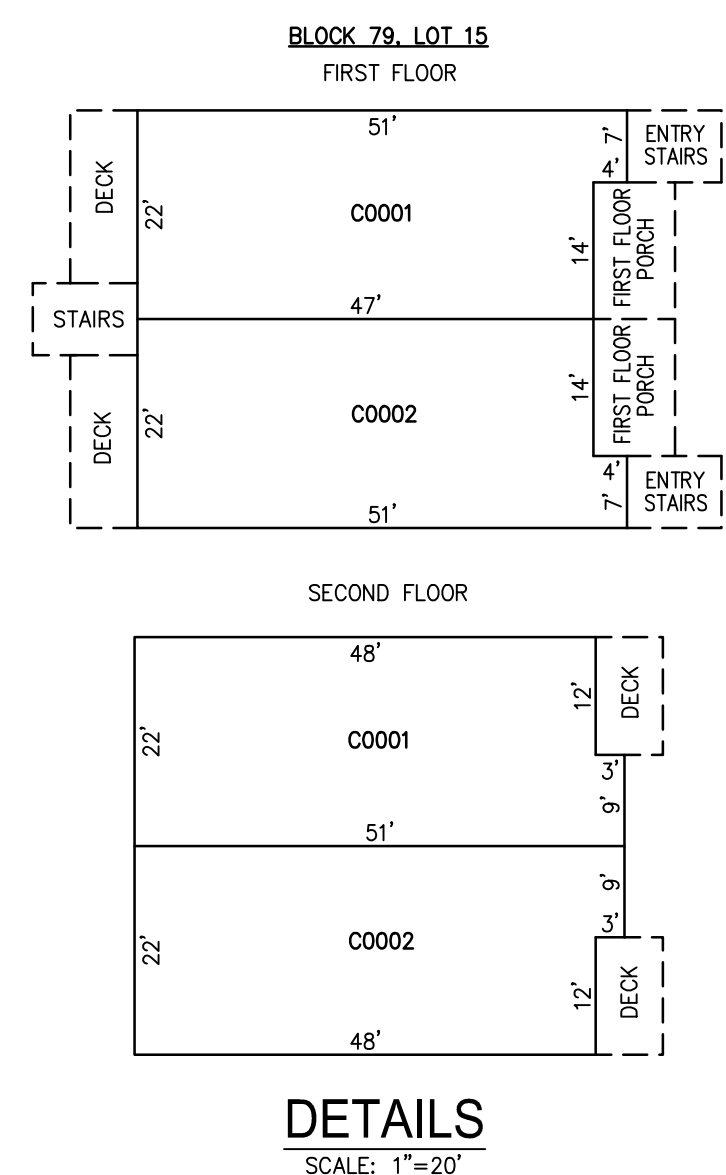

CONDO QUALIFIER	SQUARE FOOTAGE
C0001	2052 SF.
C0002	2052 SF.

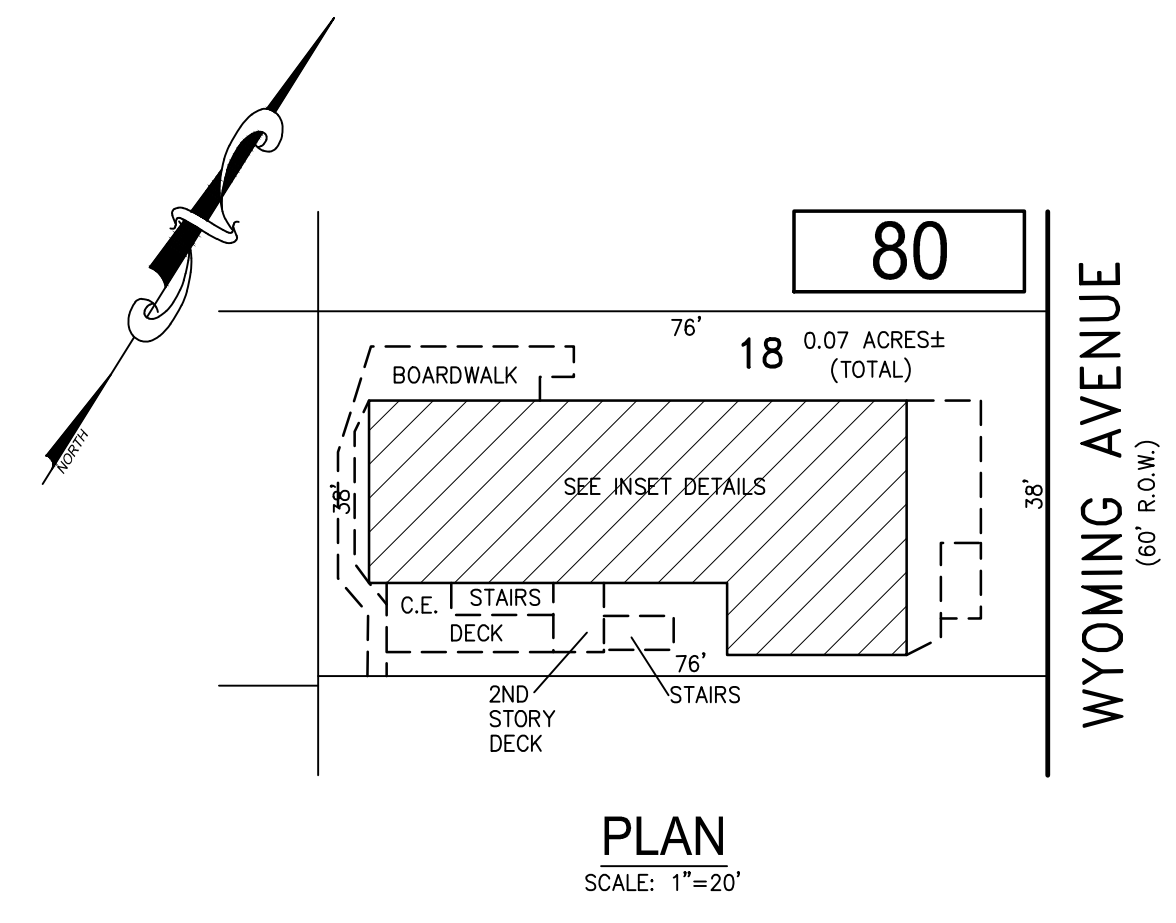

BLOCK 80, LOT 18
6 SOUTH WYOMING AVENUE CONDOMINIUM

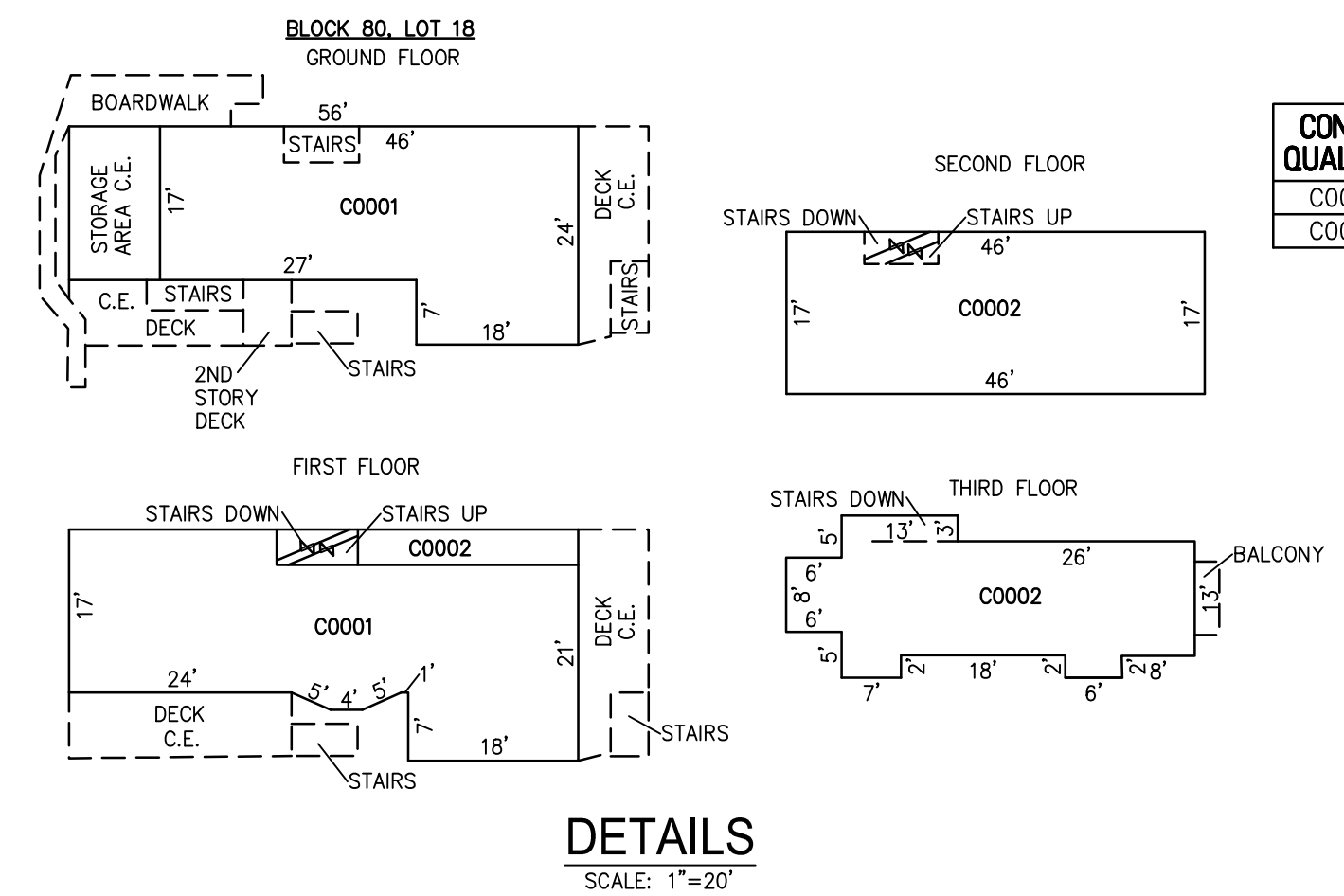

CONDO QUALIFIER	SQUARE FOOTAGE
C0001	1690 SF.
C0002	1313 SF.

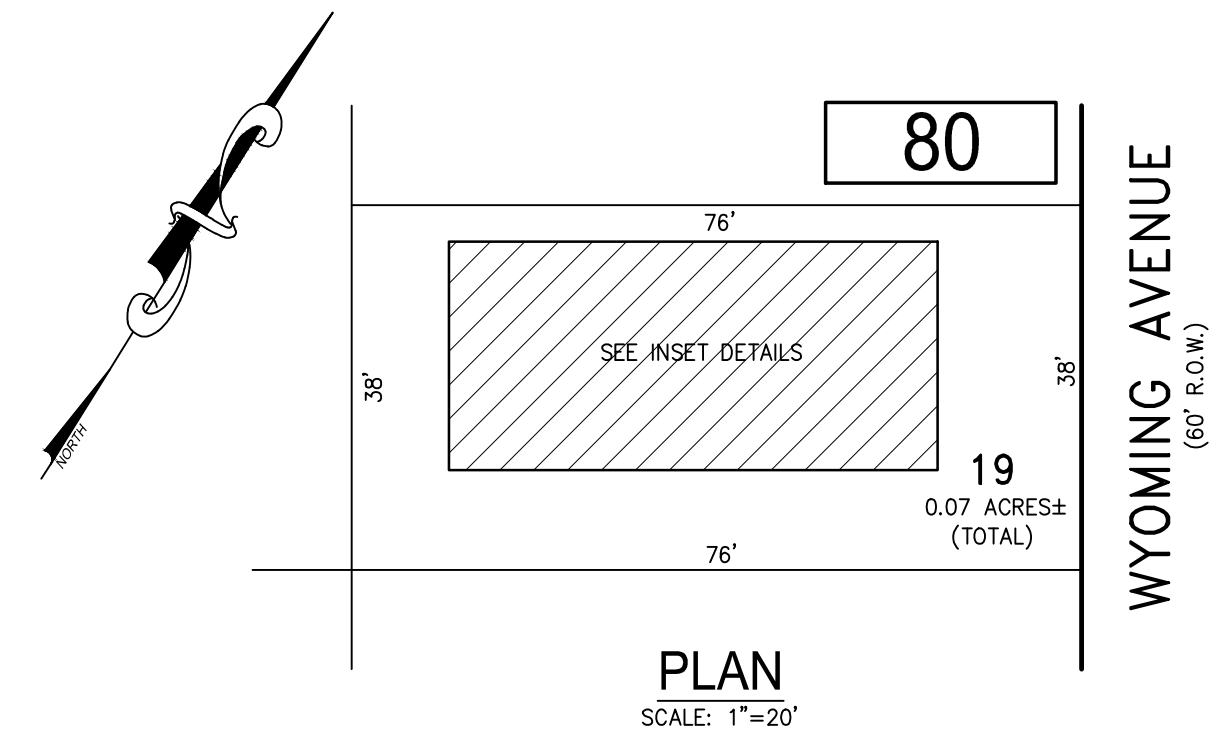

BLOCK 80, LOT 19
8 SOUTH WYOMING AVENUE CONDOMINIUM

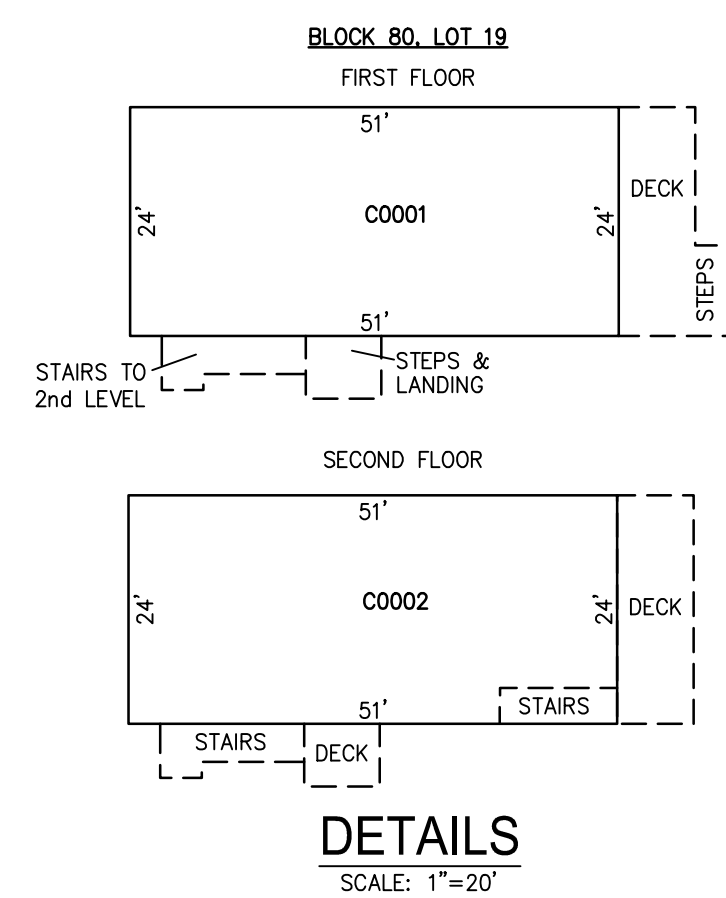

CONDO QUALIFIER	SQUARE FOOTAGE
C0001	1314 SF.
C0002	1314 SF.

BLOCK 79, LOT 15
BLOCK 80, LOT 19
BLOCK 80, LOT 18
SEE SHEET 15

"THIS TAX MAP SHEET HAS BEEN DIGITALLY REVISED USING COMPUTER-AIDED DRAFTING/DESIGN (CADD) & COORDINATE GEOMETRY (COGO). IT IS BASED ON THE ORIGINAL DIGITALLY DRAWN TAX MAP PLATE BEARING THE OFFICIAL NEW JERSEY DIVISION TAXATION APPROVAL STAMP WITH APPROVAL DATE JULY, 20, 2016. SERIAL NUMBER 1070 AND SIGNATURE OF JUDY P. MILLER, CTA, CHIEF PROPERTY ADMINISTRATION AND SHELLY REILLY, CTA, PRINCIPAL FIELD REPRESENTATIVE. THE ORIGINAL DIGITALLY DRAWN TAX MAP PLATE WITH THE OFFICIAL APPROVAL STAMP IS ON FILE WITH REMINGTON & VERNICK ENGINEERS."

TAX MAP
CITY OF VENTNOR
ATLANTIC COUNTY NEW JERSEY
SCALE: NOTED DATE: 2-23-2018

CHARLES E. ADAMSON NJ PROFESSIONAL LAND SURVEYOR LIC. NO. 42627
24 GA 28048700

REMINGTON, VERNICK & WALBERG ENGINEERS
845 N. MAIN STREET, PLEASANTVILLE, N.J. 08232
(609) 645-7100, FAX (609) 645-7076
WEB SITE ADDRESS: WWW.RVW.COM
TO SHOW CONDITIONS AS OF 2-03-2023