

REVISIONS		
8-31-2009	CRAIG F. REMINGTON	23924

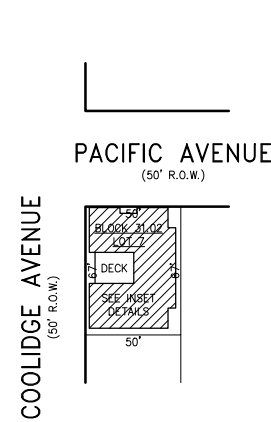

**PLAN**  
SCALE: 1"=50'

**BLOCK 31.02, LOT 7**  
**MARPORT CONDOMINIUM**  
**101 SOUTH COOLIDGE AVENUE**  
**INSET "R"**

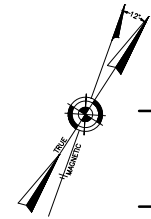
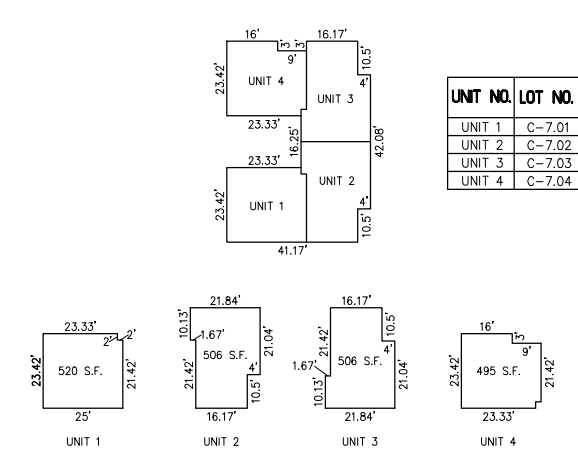

**DETAILS**  
SCALE: 1"=30'

UNIT NO.	LOT NO.
UNIT 1	C-7.01
UNIT 2	C-7.02
UNIT 3	C-7.03
UNIT 4	C-7.04

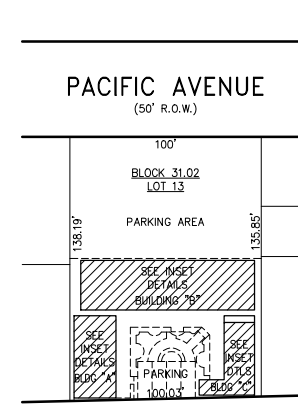
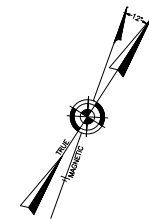

**PLAN**  
SCALE: 1"=50'

**BLOCK 31.02, LOT 13**  
**SEAWINDS CONDOMINIUM**  
**971 ATLANTIC AVENUE**  
**INSET "S"**

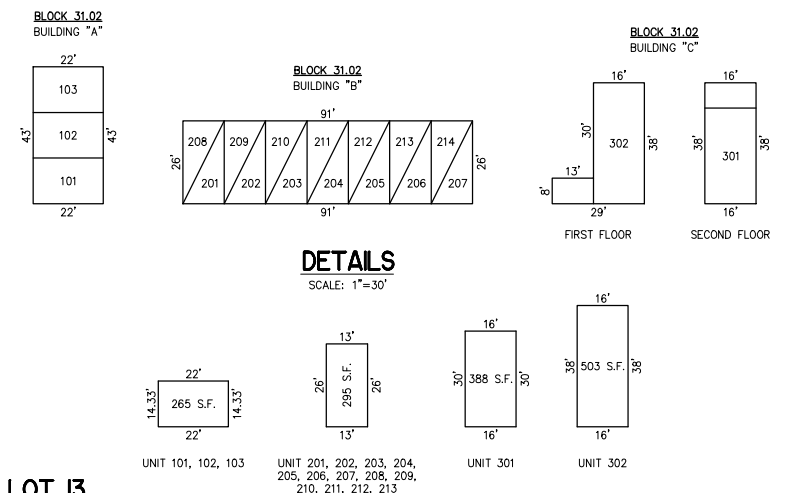

**DETAILS**  
SCALE: 1"=30'

UNIT NO.	LOT NO.
UNIT 101	C-13.101
UNIT 102	C-13.102
UNIT 103	C-13.103
UNIT 201	C-13.201
UNIT 202	C-13.202
UNIT 203	C-13.203
UNIT 204	C-13.204
UNIT 205	C-13.205
UNIT 206	C-13.206
UNIT 207	C-13.207
UNIT 208	C-13.208
UNIT 209	C-13.209
UNIT 210	C-13.210
UNIT 211	C-13.211
UNIT 212	C-13.212
UNIT 213	C-13.213
UNIT 214	C-13.214
UNIT 301	C-13.301
UNIT 302	C-13.302

NOTE: DIMENSIONS AND SQUARE FOOTAGE ARE TYPICAL FOR SIMILAR UNITS

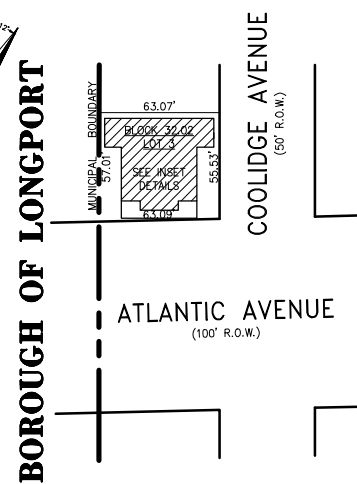
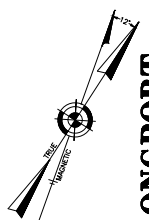

**PLAN**  
SCALE: 1"=50'

**BLOCK 32.02, LOT 3**  
**MARGATE SEAVIEW BEACH CONDOMINIUM**  
**9801 ATLANTIC AVENUE**  
**INSET "T"**

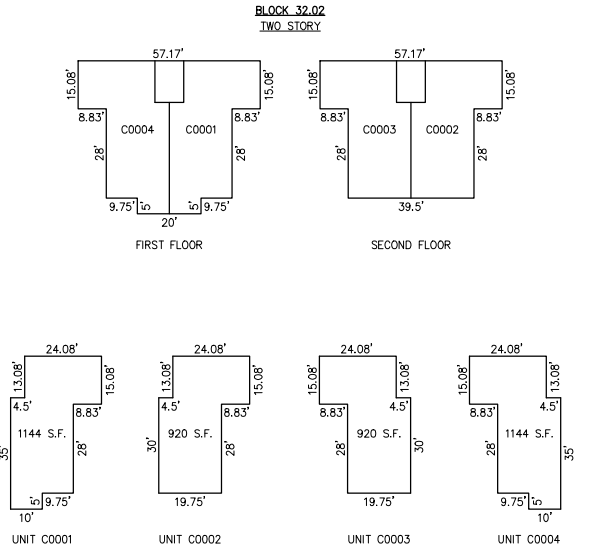

**DETAILS**  
SCALE: 1"=30'

**BLOCK 32.02, LOT 3**  
**MARGATE SEAVIEW BEACH CONDOMINIUM**  
**9801 ATLANTIC AVENUE**  
**INSET "T"**

NOTE: DIMENSIONS AND SQUARE FOOTAGE ARE TYPICAL FOR FIRST AND SECOND FLOOR.

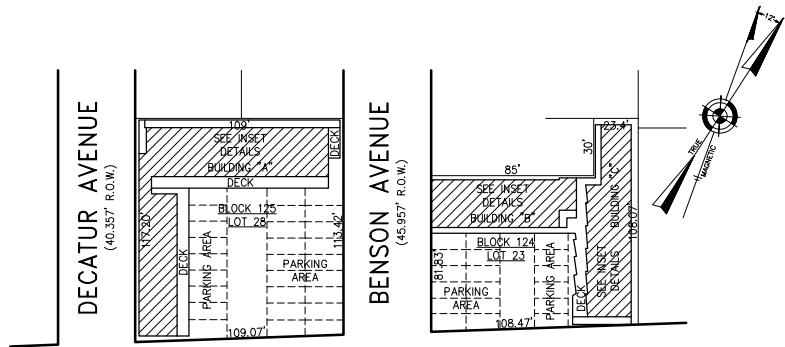

**PLAN**  
SCALE: 1"=50'

**BLOCK 124, LOT 23**  
**9105 ATLANTIC AVENUE**  
**BLOCK 125, LOT 28**  
**9201 ATLANTIC AVENUE**  
**SEAHORSE CONDOMINIUM**  
**ATLANTIC AVENUE**  
**INSET "U"**

UNIT NO.	LOT NO.
UNIT 1	C-28.01
UNIT 2	C-28.02
UNIT 3	C-28.03
UNIT 4	C-28.04
UNIT 5	C-28.05
UNIT 6	C-28.06
UNIT 7	C-28.07
UNIT 8	C-28.08
UNIT 9	C-28.09
UNIT 10	C-28.10
UNIT 11	C-28.11
UNIT 12	C-28.12
UNIT 13	C-28.13
UNIT 14	C-28.14
UNIT 15	C-28.15
UNIT 16	C-28.16
UNIT 17	C-28.17
UNIT 18	C-28.18
UNIT 19	C-28.19
UNIT 20	C-28.20
UNIT 21	C-28.21
UNIT 22	C-28.22
UNIT 23	C-23.23
UNIT 24	C-23.24
UNIT 25	C-23.25
UNIT 26	C-23.26
UNIT 27	C-23.27
UNIT 28	C-23.28
UNIT 29	C-23.29
UNIT 30	C-23.30
UNIT 31	C-23.31
UNIT 32	C-23.32
UNIT 33	C-23.33
UNIT 34	C-23.34
UNIT 35	C-23.35
UNIT 36	C-23.36
UNIT 37	C-23.37
UNIT 38	C-23.38
UNIT 39	C-23.39
UNIT 40	C-23.40
UNIT 41	C-23.41
UNIT 42	C-23.42
UNIT 43	C-23.43
UNIT 44	C-23.44

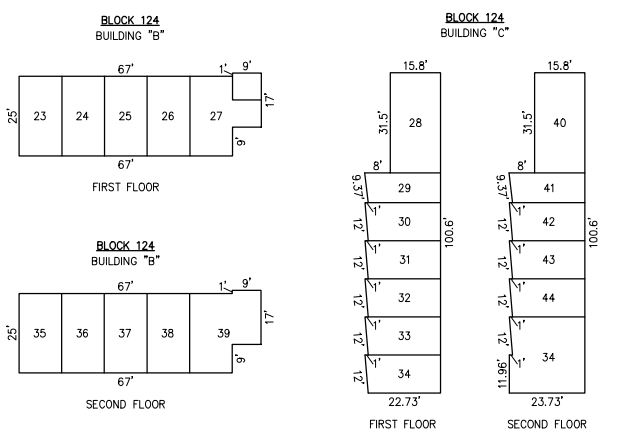
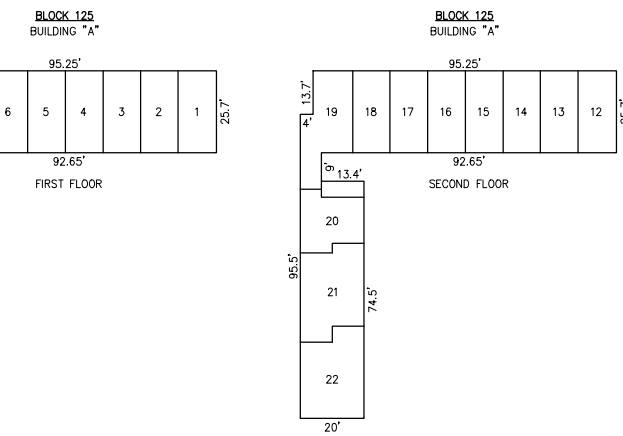
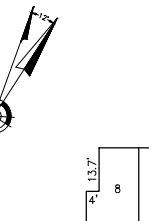

**DETAILS**  
SCALE: 1"=30'

**CONDOMINIUM DETAILS AND DIMENSIONS**  
**BLOCK 31.02, LOT 7**  
**BLOCK 31.02, LOT 13**  
**BLOCK 32.02, LOT 3**  
**BLOCK 124, LOT 23**  
**BLOCK 125, LOT 28**  
**SEE PLATE 4**

"THIS TAX MAP PLATE HAS BEEN DIGITALLY DRAWN USING COMPUTER-AIDED DRAFTING/DESIGN (CADD) & COORDINATE GEOMETRY (COGO). IT IS BASED ON THE ORIGINAL DIGITALLY DRAWN TAX MAP PLATE BEARING THE OFFICIAL NEW JERSEY DIVISION TAXATION APPROVAL STAMP WITH APPROVAL DATE 6-3-2005 SERIAL NUMBER 846 AND SIGNATURES OF SIGNERS' THOMAS J. REILLY, CHIEF, LOCAL PROPERTY, FIELD ASSISTANCE. SANTO C. DIDONATO, SUPERVISING FIELD REPRESENTATIVE. THE ORIGINAL DIGITALLY DRAWN TAX MAP PLATE WITH THE OFFICIAL APPROVAL STAMP IS ON FILE WITH REMINGTON, VERNICK & WALBERG ENGINEERS."

**TAX MAP**  
**CITY OF MARGATE**  
ATLANTIC COUNTY NEW JERSEY  
SCALE: AS NOTED DATE: 1-30-2004  
**CRAIG F. REMINGTON LAND SURVEYOR LIC. NO. 23924**  
**REMGTON, VERNICK & WALBERG ENGINEERS**  
24 GA 28048700  
845 N. MAIN STREET, PLEASANTVILLE, N.J. 08232  
(609) 645-700, FAX (609) 645-7076  
WEB SITE ADDRESS: WWW.RVE.COM