

REVISIONS		
4-13-2007	CRAIG F. REMINGTON	23924

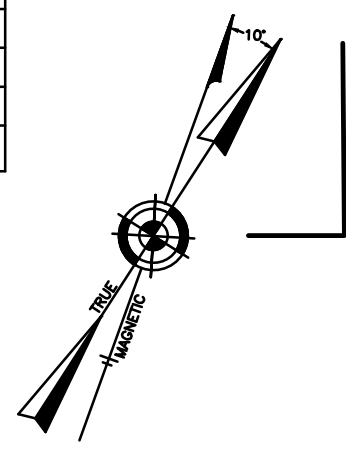

VENTNOR AVENUE
(COUNTY ROUTE NO. 629)
(80' R.O.W.)

DOUGLASS AVENUE
(50' R.O.W.)

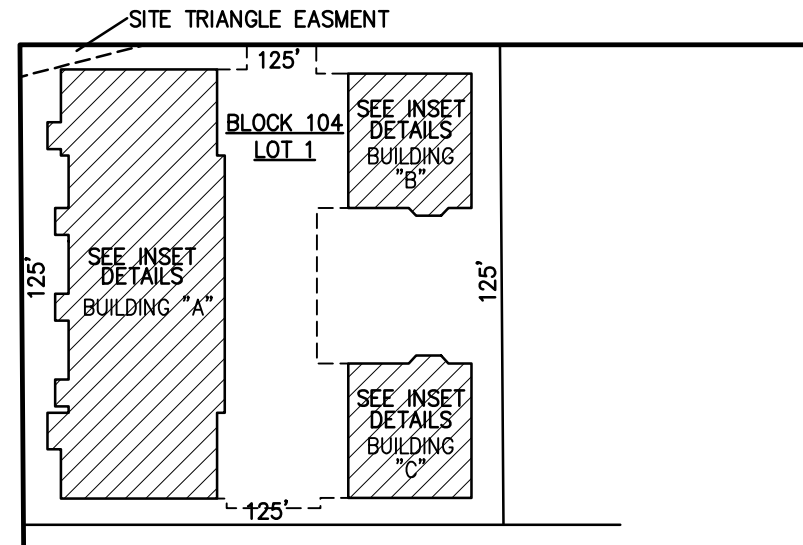

PLAN
SCALE: 1"=50'

UNIT NO.	LOT NO.
C0001	C-01
C0002	C-02
C0003	C-03
C0004	C-04
C0005	C-05

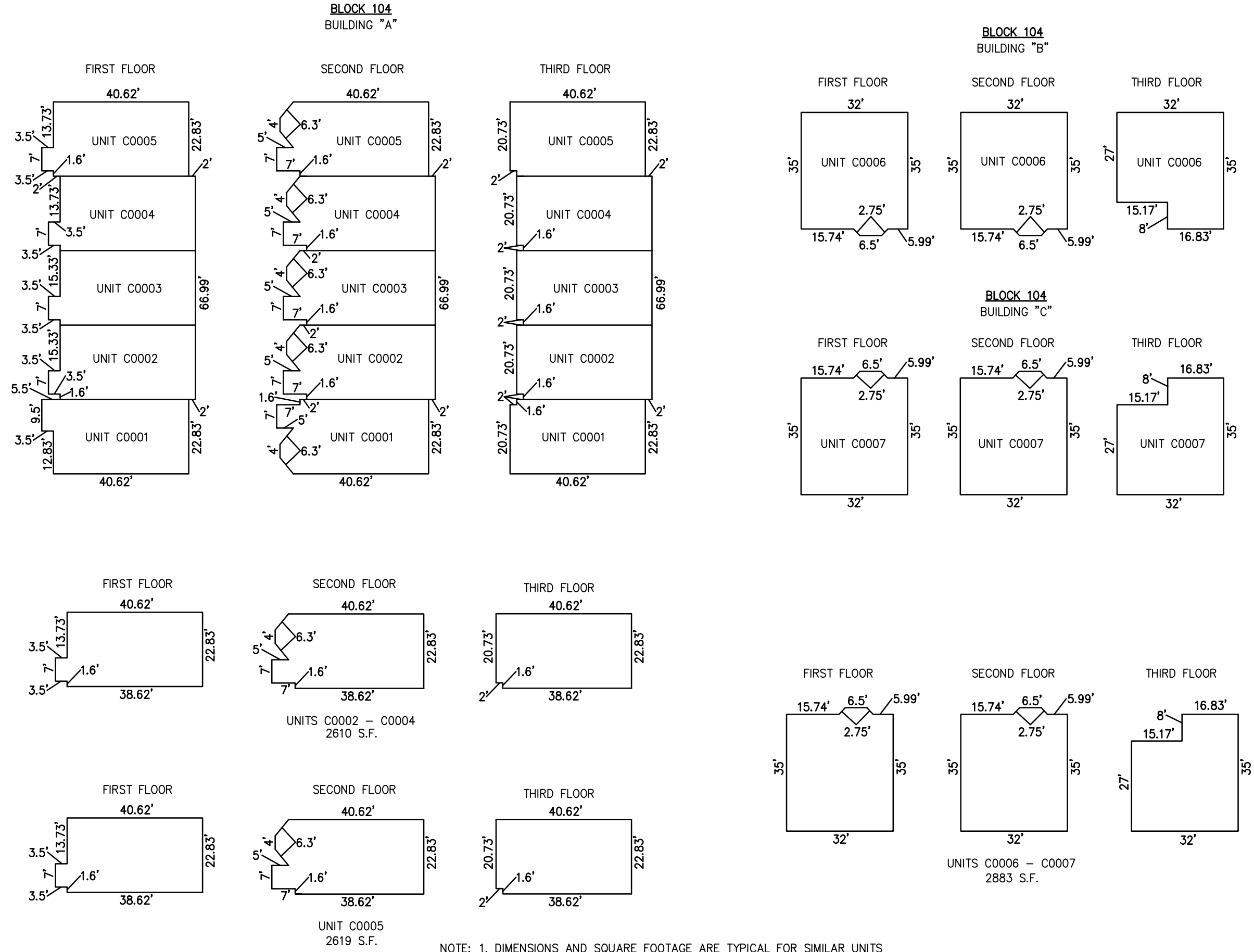

NOTE: 1. DIMENSIONS AND SQUARE FOOTAGE ARE TYPICAL FOR SIMILAR UNITS

DETAILS
SCALE: 1"=30'

BLOCK 104, LOT 1
OCEAN WALK CONDOMINIUM
1 SOUTH DOUGLASS AVENUE
INSET "TTTT"

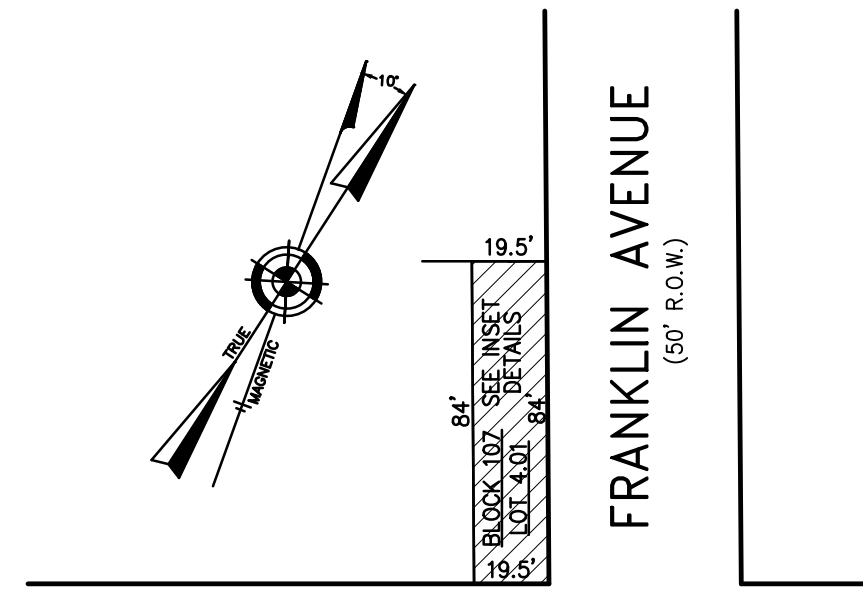

ATLANTIC AVENUE
(100' R.O.W.)



PLAN
SCALE: 1"=50'

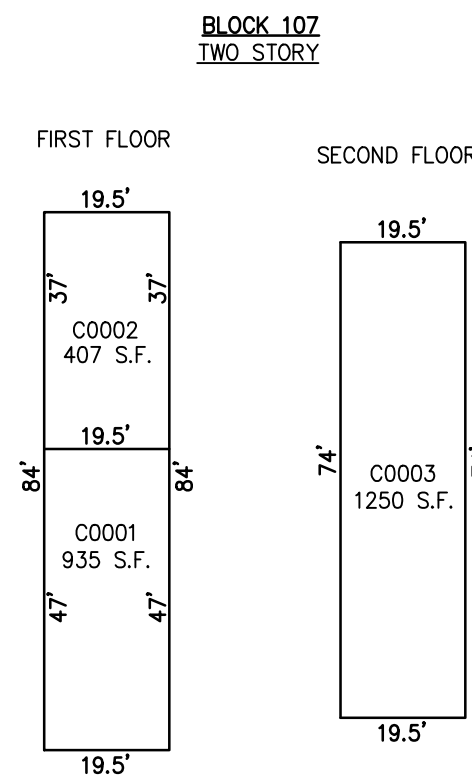

DETAILS
SCALE: 1"=30'

BLOCK 107, LOT 4.01
FRANKLIN BEACH CONDOMINIUM
7901 ATLANTIC AVENUE
INSET "WW"

CONDOMINIUM DETAILS AND DIMENSIONS
BLOCK 104, LOT 1
BLOCK 107, LOT 4.01
BLOCK 105, LOT 3
SEE PLATE I

UNIT NO.	LOT NO.
C0001	C-01
C0002	C-02
C0003	C-03

"THIS TAX MAP PLATE HAS BEEN DIGITALLY DRAWN USING COMPUTER-AIDED DRAFTING/DESIGN (CADD) & COORDINATE GEOMETRY (COGO). IT IS BASED ON THE ORIGINAL DIGITALLY DRAWN TAX MAP PLATE BEARING THE OFFICIAL NEW JERSEY DIVISION TAXATION APPROVAL STAMP WITH APPROVAL DATE 6-3-2005, SERIAL NUMBER 846 AND SIGNATURES OF SIGNERS' THOMAS J. REILLY, CHIEF, LOCAL PROPERTY, FIELD ASSISTANCE. SANTO C. DIDONATO, SUPERVISING FIELD REPRESENTATIVE. THE ORIGINAL DIGITALLY DRAWN TAX MAP PLATE WITH THE OFFICIAL APPROVAL STAMP IS ON FILE WITH REMINGTON, VERNICK & WALBERG ENGINEERS."

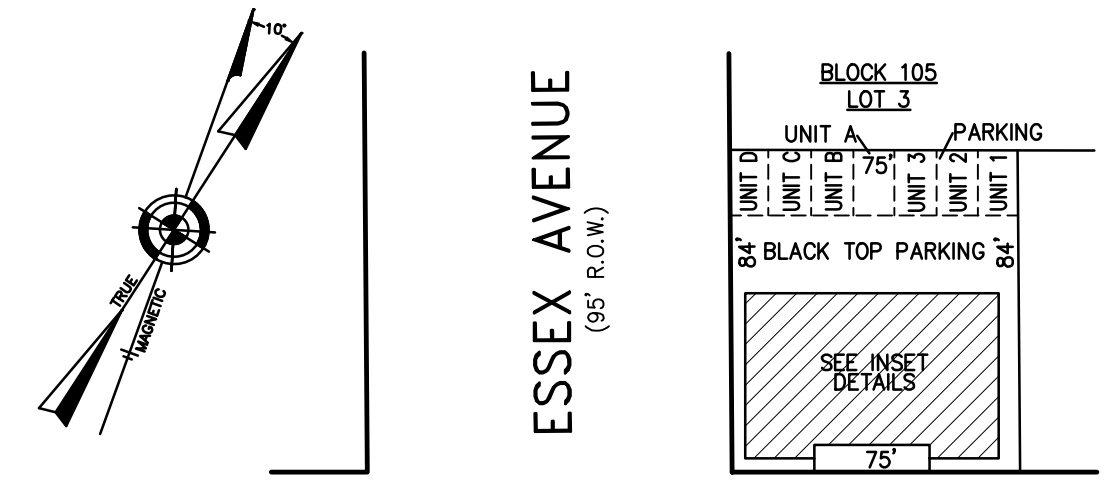

ATLANTIC AVENUE
(100' R.O.W.)

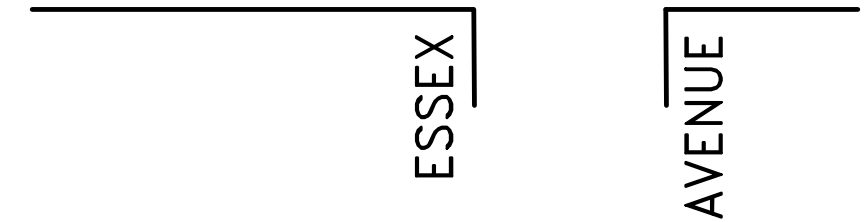

PLAN
SCALE: 1"=50'

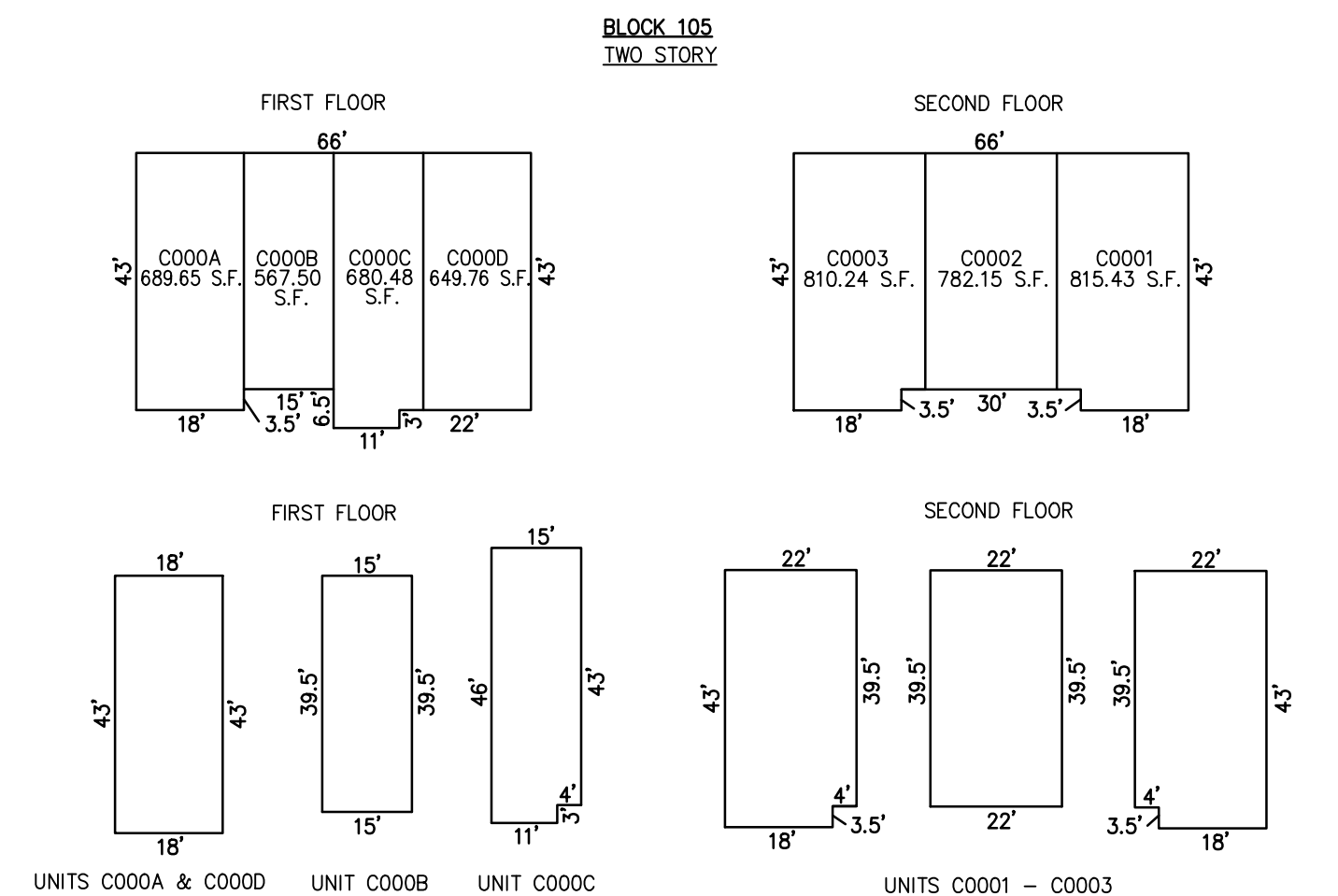

NOTE: 1. DIMENSIONS AND SQUARE FOOTAGE ARE TYPICAL FOR SIMILAR UNITS

DETAILS
SCALE: 1"=30'

BLOCK 105, LOT 3
781 ATLANTIC CONDOMINIUM
781 ATLANTIC AVENUE
INSET "1 C"

UNIT NO.	LOT NO.
C000A	C-01
C000B	C-02
C000C	C-03
C000D	C-04
C0001	C-05
C0002	C-06
C0003	C-07

TAX MAP
CITY OF MARGATE

ATLANTIC COUNTY NEW JERSEY
SCALE: AS NOTED DATE: 1-30-2004

CRAIG F. REMINGTON LAND SURVEYOR LIC. NO. 23924



REMINGTON, VERNICK & WALBERG ENGINEERS
24 GA 28048700
845 N. MAIN STREET, PLEASANTVILLE, NJ 08232
(609) 645-7100, FAX (609) 645-7076
WEB SITE ADDRESS: WWW.RVW.COM