

REVISIONS

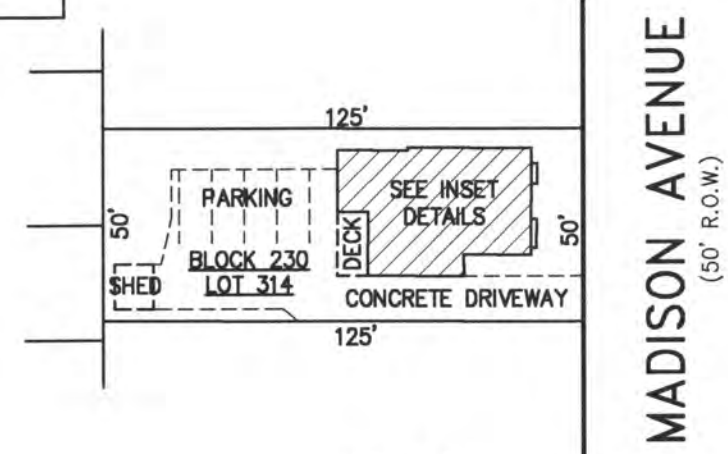

PLAN
SCALE: 1"=50'

BLOCK 230
TWO STORY

UNIT NO.	LOT NO.
C0001	C-01
C0002	C-01

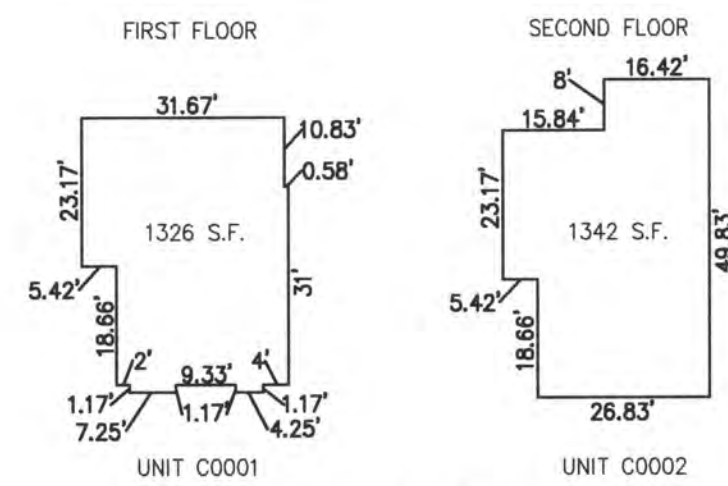

DETAILS
SCALE: 1"=30'

BLOCK 230, LOT 314
18 NORTH MADISON AVENUE
INSET "NNNN"

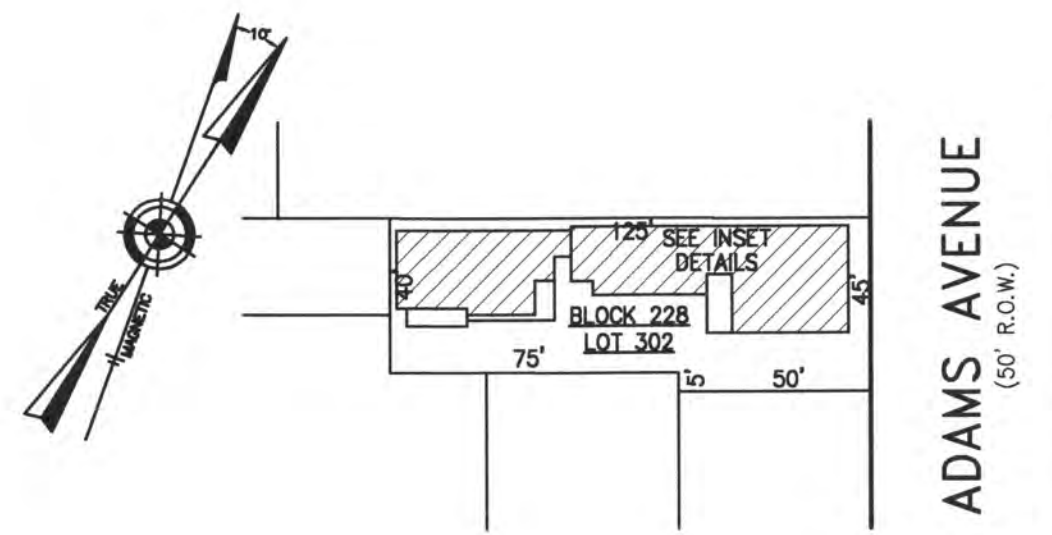

PLAN
SCALE: 1"=50'

BLOCK 228
FIRST FLOOR

UNIT NO.	LOT NO.
C0001	C-01
C0002	C-02
C0003	C-03
C0004	C-04
C0005	C-05
C0006	C-06

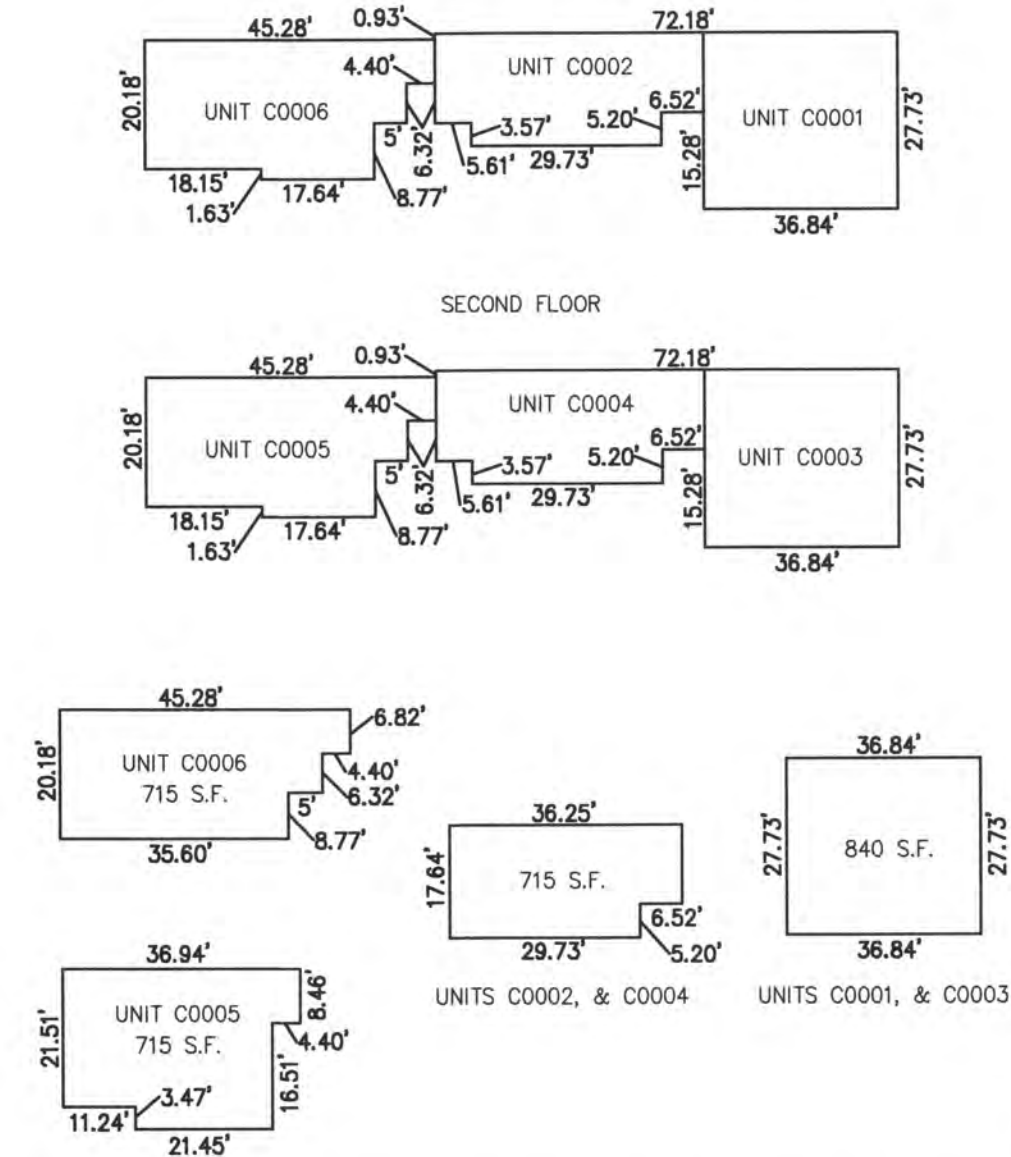

NOTE: 1. DIMENSIONS AND SQUARE FOOTAGE ARE TYPICAL FOR SIMILAR UNITS
2. UNIT NUMBERS ARE ALSO LOT NUMBERS

DETAILS
SCALE: 1"=30'

BLOCK 228, LOT 302
6 NORTH ADAMS AVENUE
6 NORTH ADAMS AVENUE
INSET "OOOO"



WASHINGTON AVENUE
(62' R.O.W.)

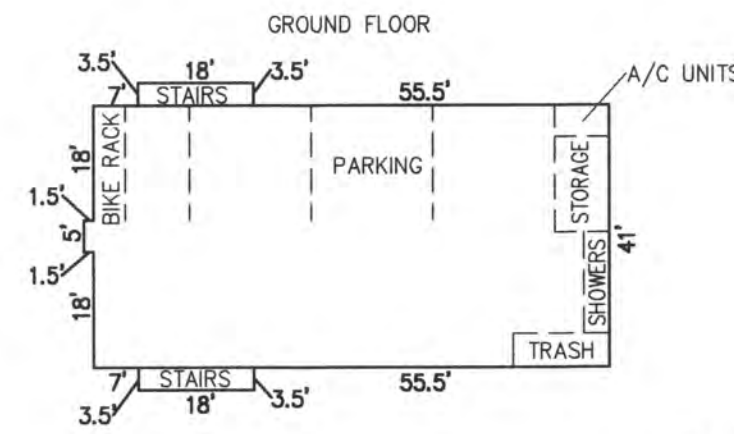

GROUND FLOOR

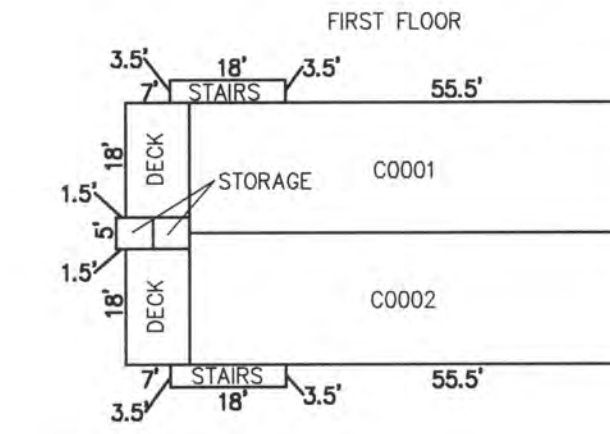

FIRST FLOOR

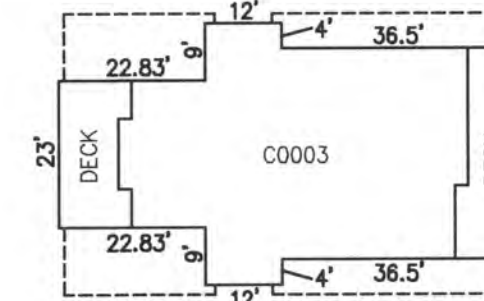

SECOND FLOOR

UNIT NO.	LOT NO.
C0001	C-01
C0002	C-02
C0003	C-03

DETAILS
SCALE: 1"=30'

BLOCK 326, LOT 43
115 NORTH WASHINGTON AVENUE CONDOMINIUM
115 NORTH WASHINGTON AVENUE
INSET "SSSS"

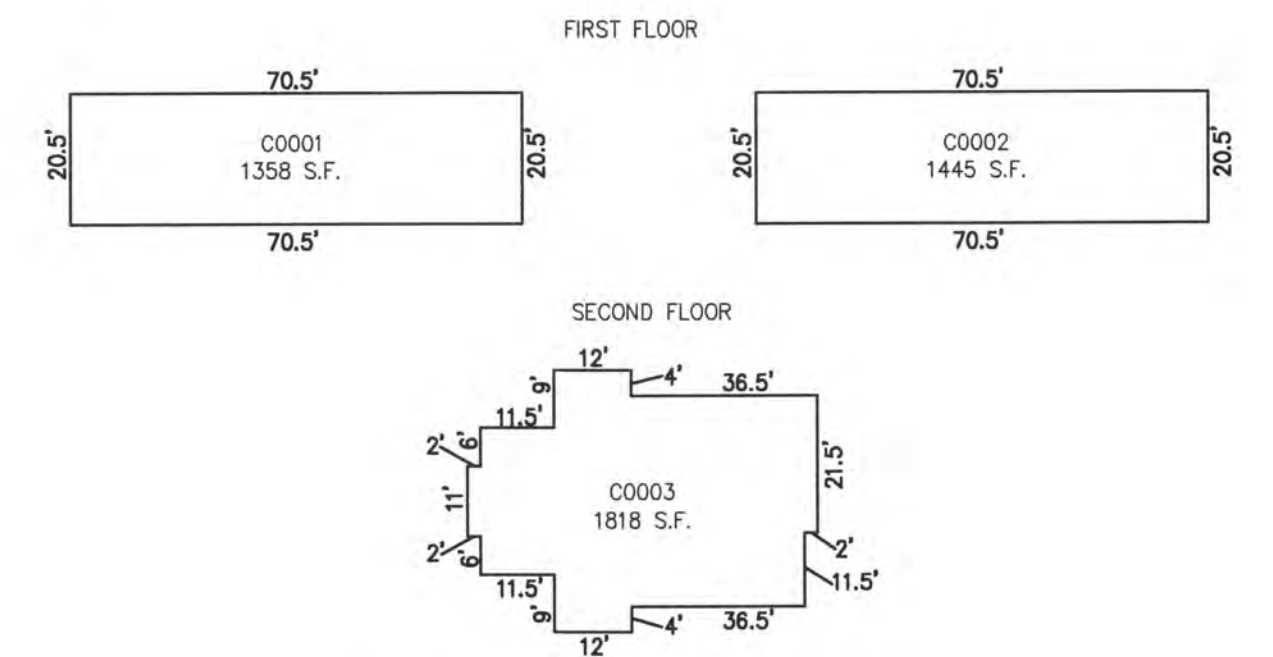

NOTE: UNIT NUMBERS ARE ALSO LOT NUMBERS

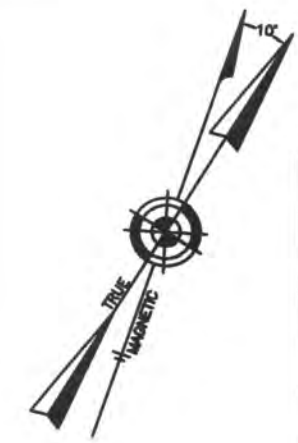

MONROE AVENUE
(50' R.O.W.)

PLAN
SCALE: 1"=50'

BLOCK 330
TWO STORY

UNIT NO.	LOT NO.
C000A	C-01
C000B	C-02

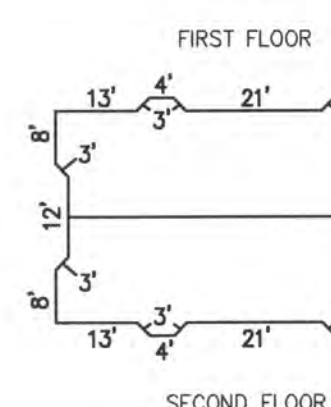

FIRST FLOOR

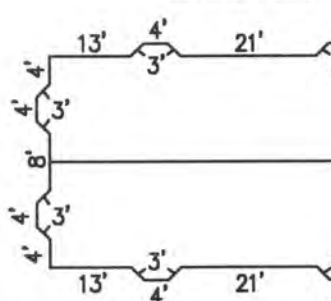

SECOND FLOOR

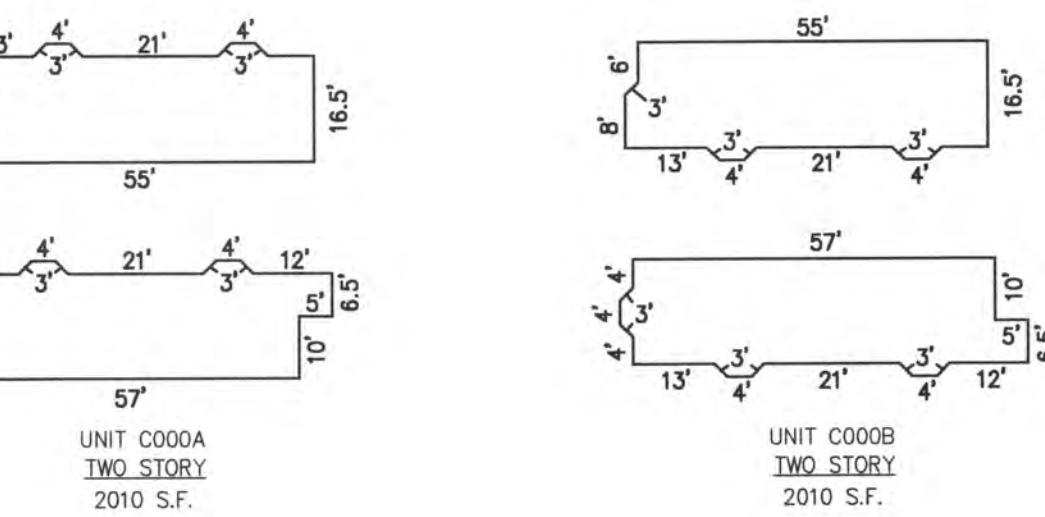

NOTE: 1. DIMENSIONS AND SQUARE FOOTAGE ARE TYPICAL FOR SIMILAR UNITS
2. UNIT NUMBERS ARE ALSO LOT NUMBERS

DETAILS
SCALE: 1"=30'

BLOCK 330, LOT 407
MONROE MANOR CONDOMINIUM
113 NORTH MONROE AVENUE
INSET "QQQQ"



MONROE AVENUE
(50' R.O.W.)

PLAN
SCALE: 1"=50'

BLOCK 330, LOT 411
SEABREEZE CONDOMINIUM
119 NORTH MONROE AVENUE
INSET "RRRR"

UNIT NO.	LOT NO.
C000A	C-01
C000B	C-02

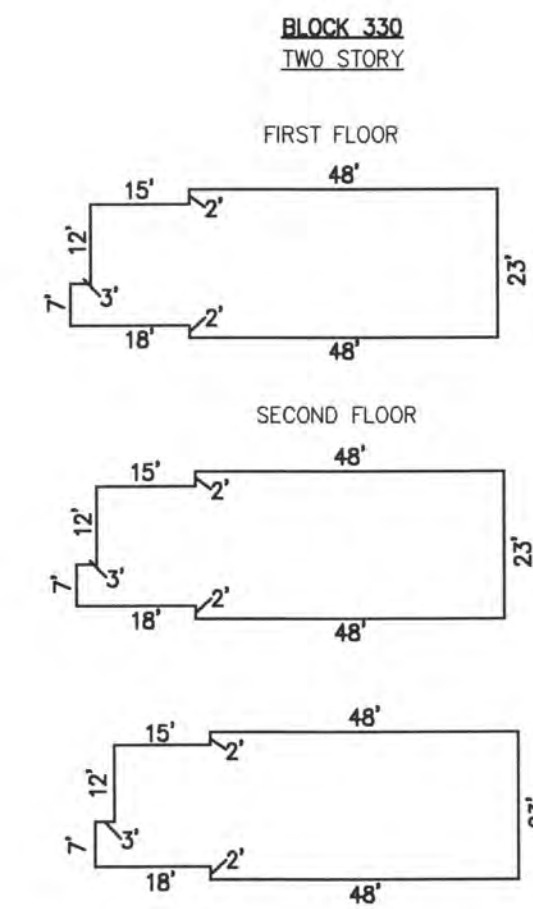

UNIT C000A & C000B
FIRST & SECOND FLOOR
1360 S.F.

NOTE: DIMENSIONS AND SQUARE FOOTAGE ARE TYPICAL FOR FIRST AND SECOND FLOOR

DETAILS
SCALE: 1"=30'

CONDOMINIUM DETAILS AND DIMENSIONS

- BLOCK 228, LOT 302
- BLOCK 326, LOT 43
- BLOCK 230, LOT 314
- BLOCK 330, LOT 411
- BLOCK 330, LOT 407
- SEE PLATE 5

TAX MAP
CITY OF MARGATE

ATLANTIC COUNTY NEW JERSEY
SCALE: AS NOTED DATE: 1-30-2004

CRAIG F. REMINGTON LAND SURVEYOR LIC. NO. 23924



REMINGTON, VERNICK & WALBERG ENGINEERS
24 GA 28048700
845 N. MAIN STREET, PLEASANTVILLE, N.J. 08232
(609) 645-7100, FAX (609) 645-7076
WEB SITE ADDRESS: WWW.RVE.COM