

REVISIONS		
DATE	NAME	NO.

NOTE:
THIS SHEET HAS BEEN DRAWN USING COMPUTER AIDED DRAFTING/DESIGN (CADD) AND COORDINATE GEOMETRY (COGO).

NEW HAVEN AVENUE
(60' R.O.W.)

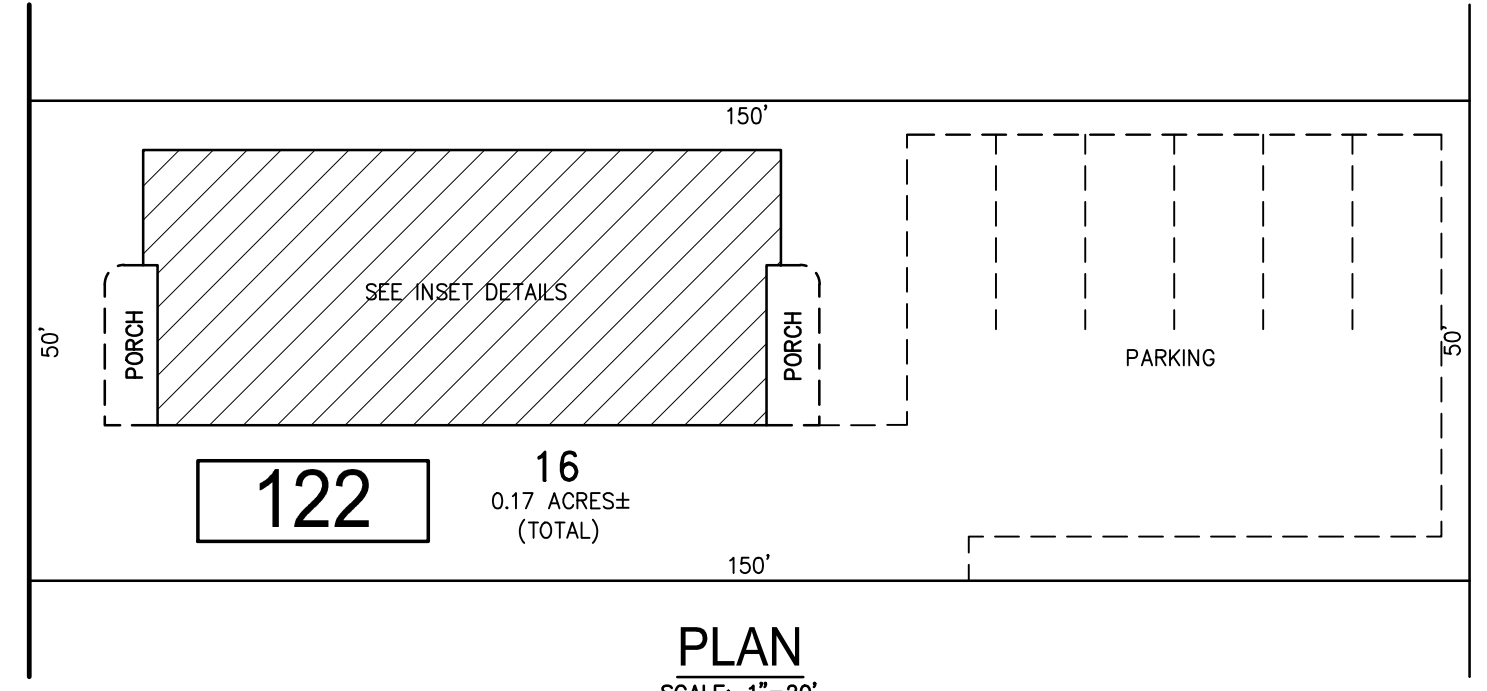

PLAN
SCALE: 1"=20'

BLOCK 122, LOT 16
FIRST FLOOR

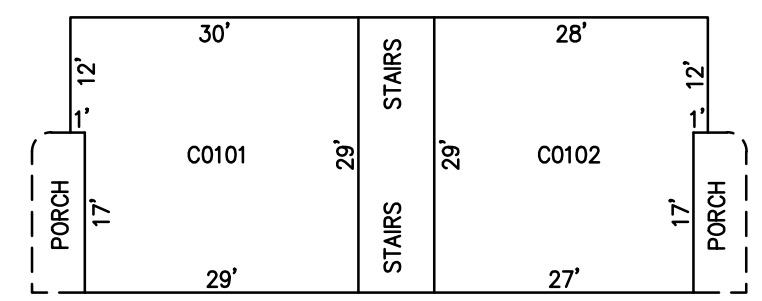

SECOND FLOOR

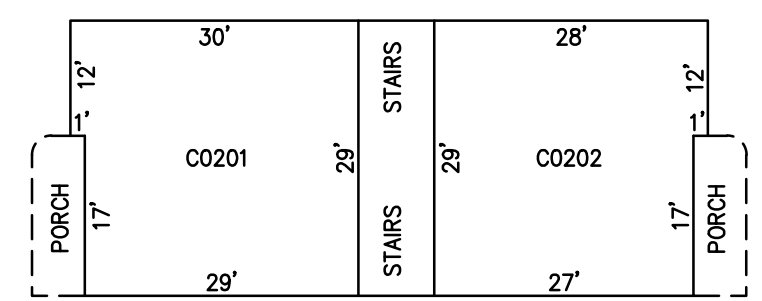

THIRD FLOOR

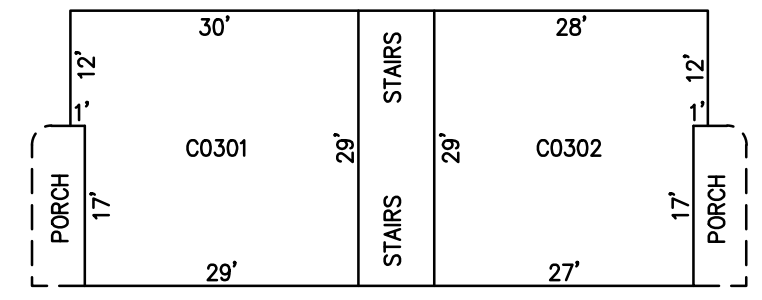

CONDO QUALIFIER	SQUARE FOOTAGE
C0101	906 SF.
C0102	906 SF.
C0201	906 SF.
C0202	906 SF.
C0301	906 SF.
C0302	906 SF.

BLOCK 122, LOT 16
NEW HAVEN GARDENS CONDOMINIUM
5 NORTH NEW HAVEN AVENUE

NEW HAVEN AVENUE
(60' R.O.W.)

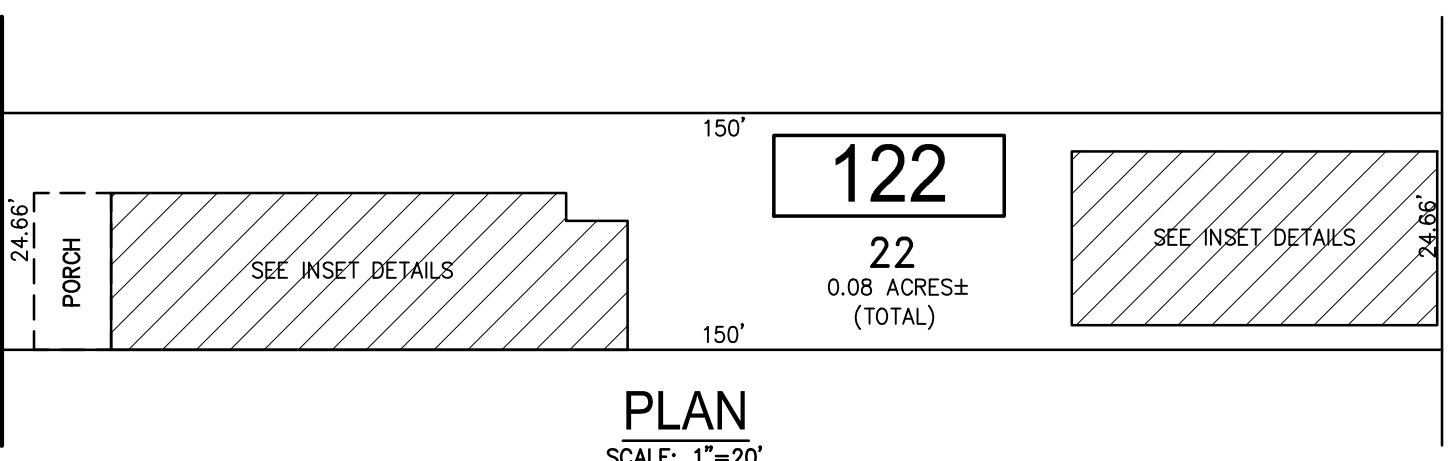

PLAN
SCALE: 1"=20'

BLOCK 122, LOT 22

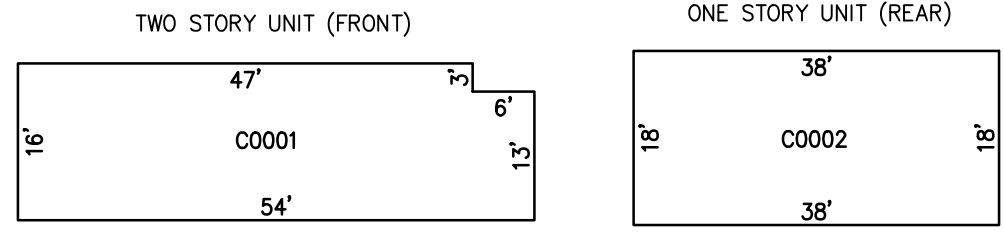

DETAILS
SCALE: 1"=20'

BLOCK 122, LOT 22
17 NORTH NEW HAVEN AVENUE CONDOMINIUM

CONDO QUALIFIER	SQUARE FOOTAGE
C0001	1436 SF.
C0002	665 SF.

NEWPORT AVENUE
(60' R.O.W.)

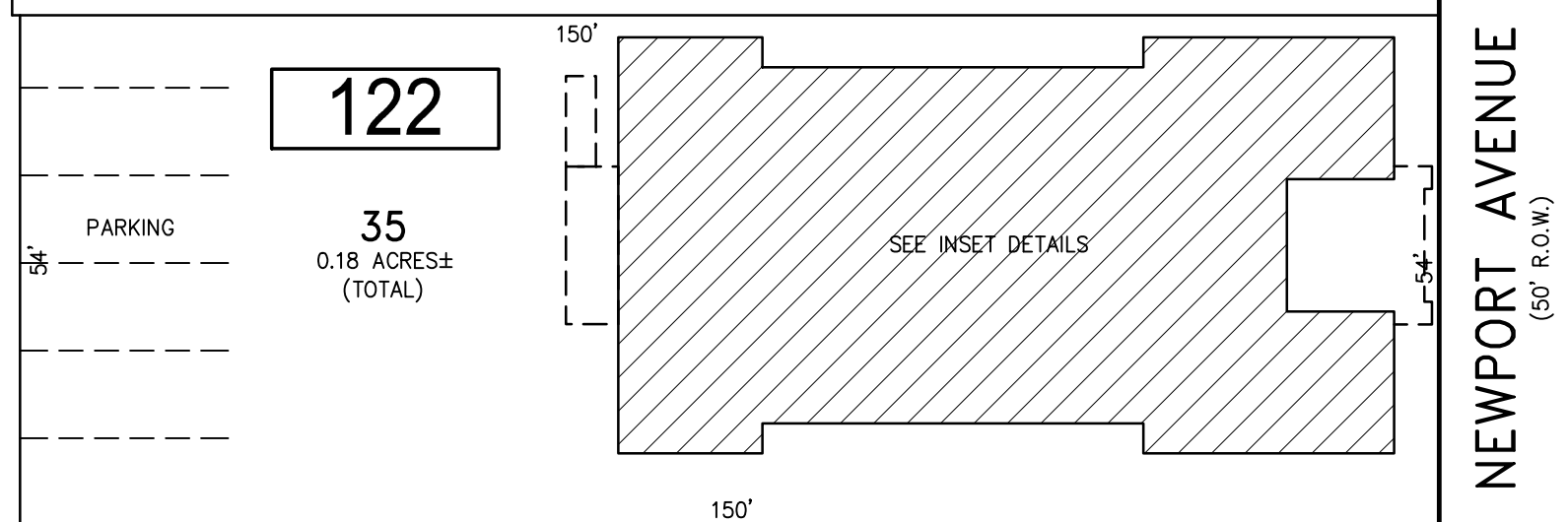

PLAN
SCALE: 1"=20'

BLOCK 122, LOT 35
FIRST FLOOR

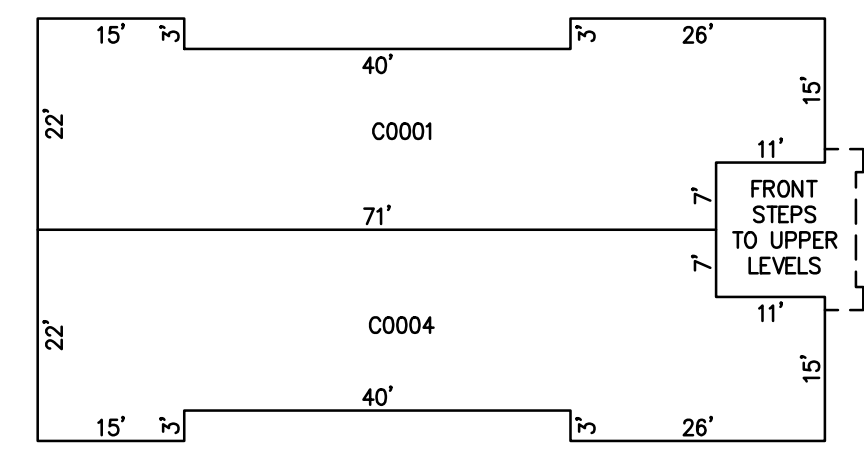

SECOND FLOOR

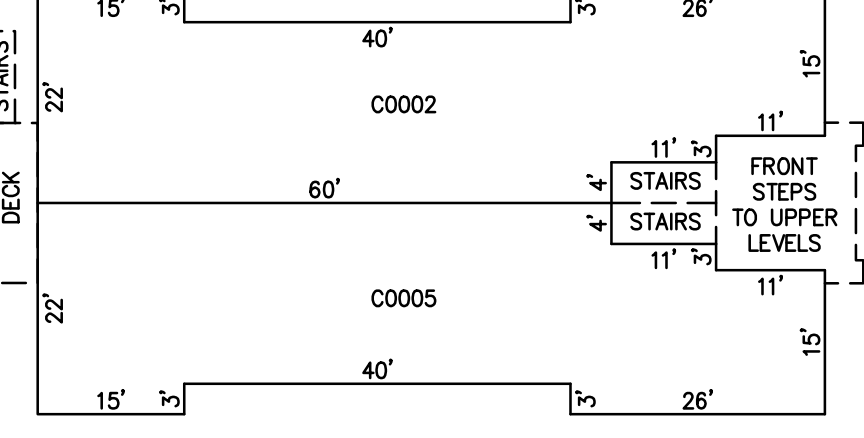

THIRD FLOOR

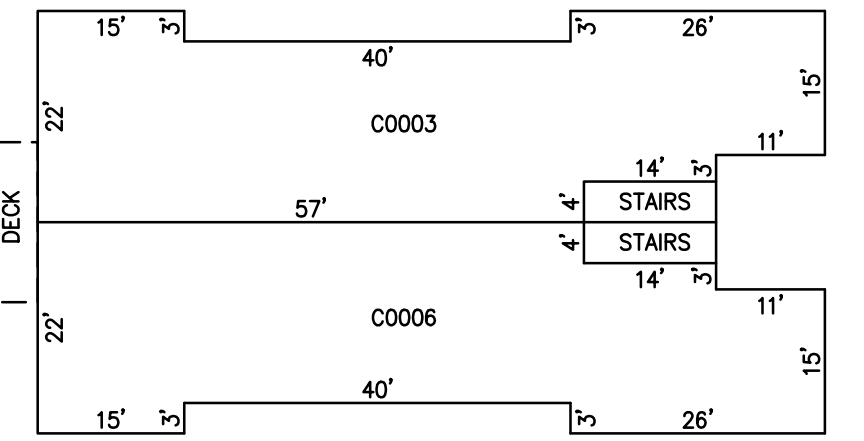

CONDO QUALIFIER	SQUARE FOOTAGE
C0001	1597 SF.
C0002	1553 SF.
C0003	1553 SF.
C0004	1597 SF.
C0005	1553 SF.
C0006	1553 SF.

DETAILS
SCALE: 1"=20'

BLOCK 122, LOT 35
NEWPORT NORTH CONDOMINIUM
18-20 NORTH NEWPORT AVENUE

NEWPORT AVENUE
(60' R.O.W.)

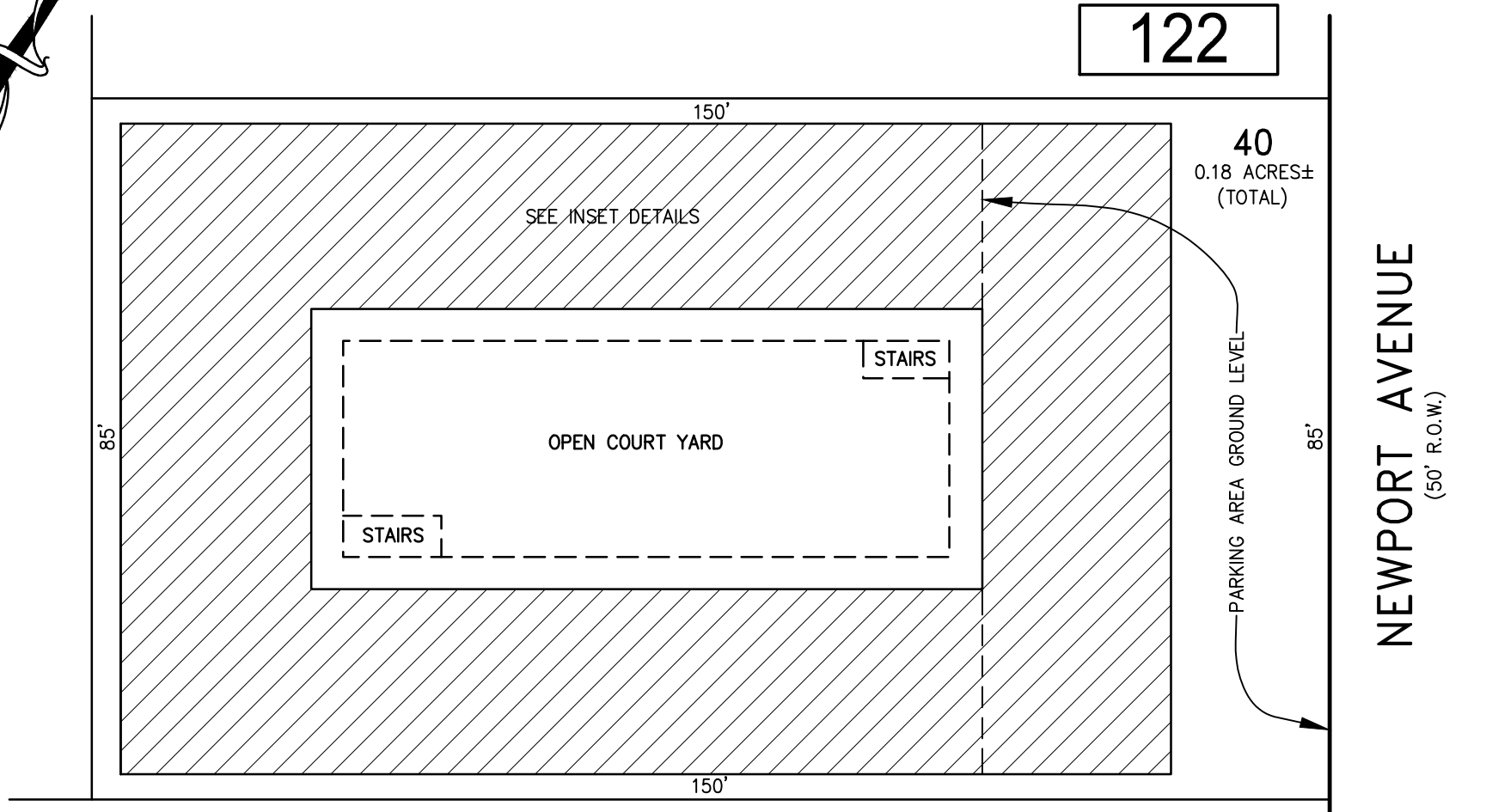

PLAN
SCALE: 1"=20'

BLOCK 122, LOT 40
FIRST FLOOR

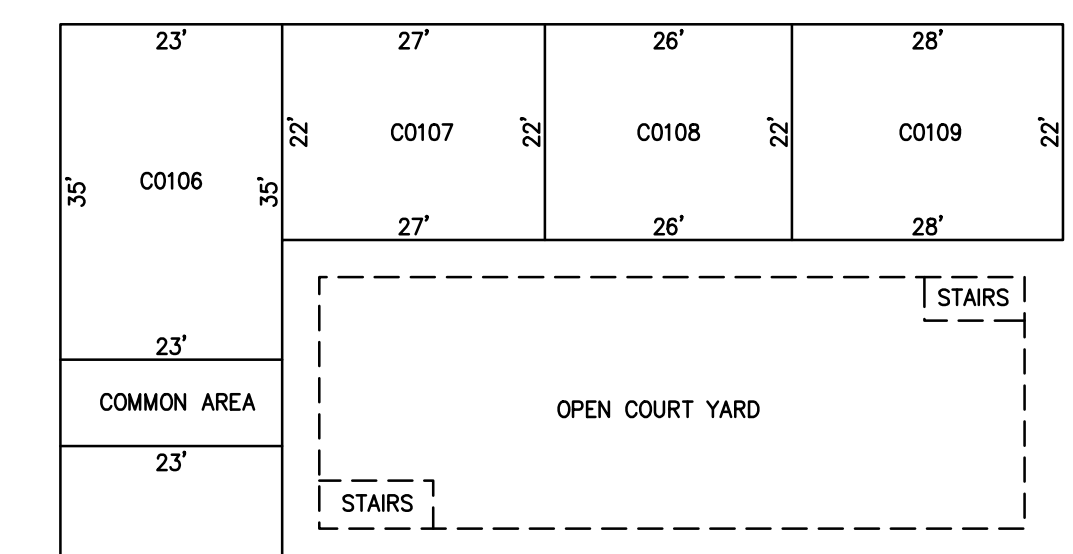

SECOND FLOOR

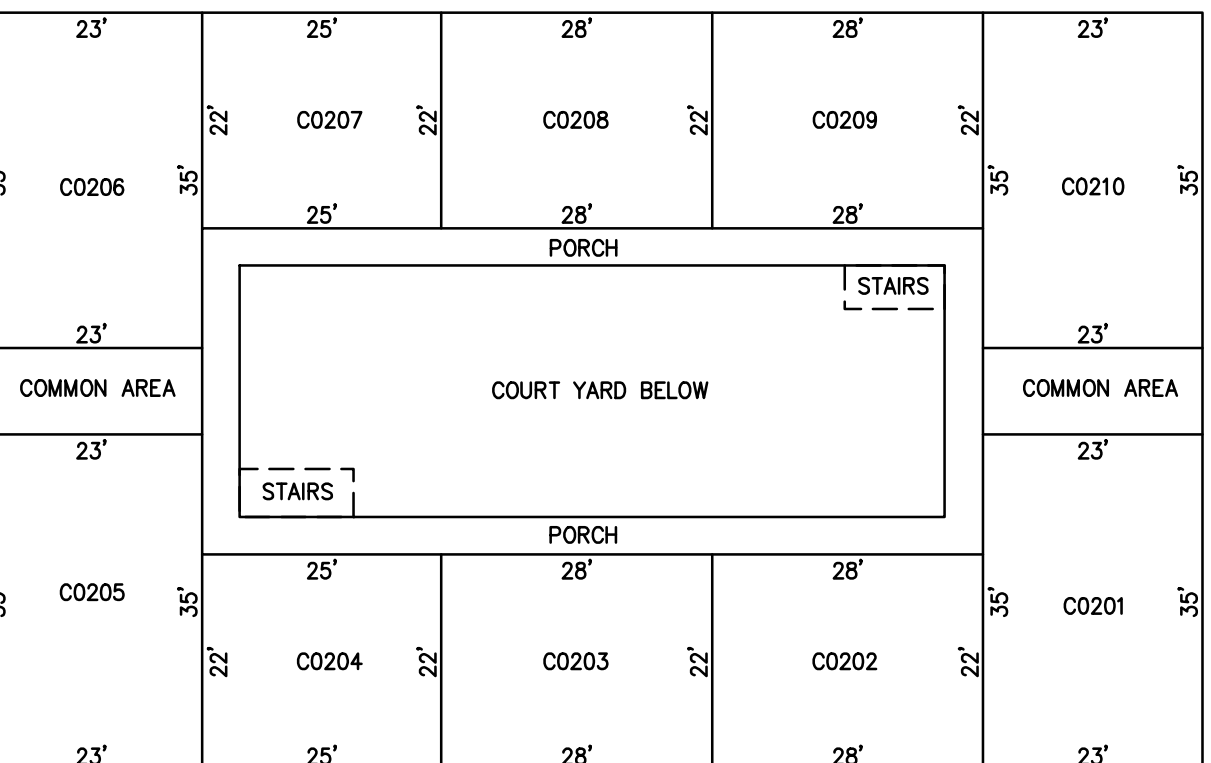

DETAILS
SCALE: 1"=20'

BLOCK 122, LOT 40
NEWPORT GARDENS CONDOMINIUM
6 NORTH NEWPORT AVENUE

CONDO QUALIFIER	SQUARE FOOTAGE
C0102	570 SF.
C0103	570 SF.
C0104	570 SF.
C0105	794 SF.
C0106	794 SF.
C0107	570 SF.
C0108	570 SF.
C0109	570 SF.
C0201	794 SF.
C0202	570 SF.
C0203	570 SF.
C0204	570 SF.
C0205	794 SF.
C0206	794 SF.
C0207	570 SF.
C0208	570 SF.
C0209	570 SF.
C0210	794 SF.

BLOCK 122, LOT 16
BLOCK 122, LOT 22
BLOCK 122, LOT 35
BLOCK 122, LOT 40
SEE SHEET 22

"THIS TAX MAP SHEET HAS BEEN DIGITALLY REVISED USING COMPUTER-AIDED DRAFTING/DESIGN (CADD) & COORDINATE GEOMETRY (COGO). IT IS BASED ON THE ORIGINAL DIGITALLY DRAWN TAX MAP PLATE BEARING THE OFFICIAL NEW JERSEY DIVISION TAXATION APPROVAL STAMP WITH APPROVAL DATE JULY, 20, 2016. SERIAL NUMBER 1070 AND SIGNATURE OF JUDY P. MILLER, C.T.A. CHIEF PROPERTY ADMINISTRATION AND SHELLY REILLY, C.T.A. PRINCIPAL FIELD REPRESENTATIVE. THE ORIGINAL DIGITALLY DRAWN TAX MAP PLATE WITH THE OFFICIAL APPROVAL STAMP IS ON FILE WITH REMINGTON & VERNICK ENGINEERS."

TAX MAP
CITY OF VENTNOR
ATLANTIC COUNTY NEW JERSEY
SCALE: NOTED DATE: 2-19-2015

CHARLES E. ADAMSON NJ PROFESSIONAL LAND SURVEYOR LIC. NO. 42627
24 GA 28048700

REMINOTON, VERNICK & WALBERG ENGINEERS
845 N. MAIN STREET, PLEASANTVILLE, NJ 08232
(609) 645-7000, FAX (609) 645-7076
WEB SITE ADDRESS: WWW.RVW.COM
TO SHOW CONDITIONS AS OF 2-19-2019