

REVISIONS		
4-13-2007	CRAIG F. REMINGTON	23924

UNIT NO.	LOT NO.
C0001	C-01
C0002	C-02
C0003	C-03
C0004	C-04
C0005	C-05
C0006	C-06
C0007	C-07
C0008	C-08

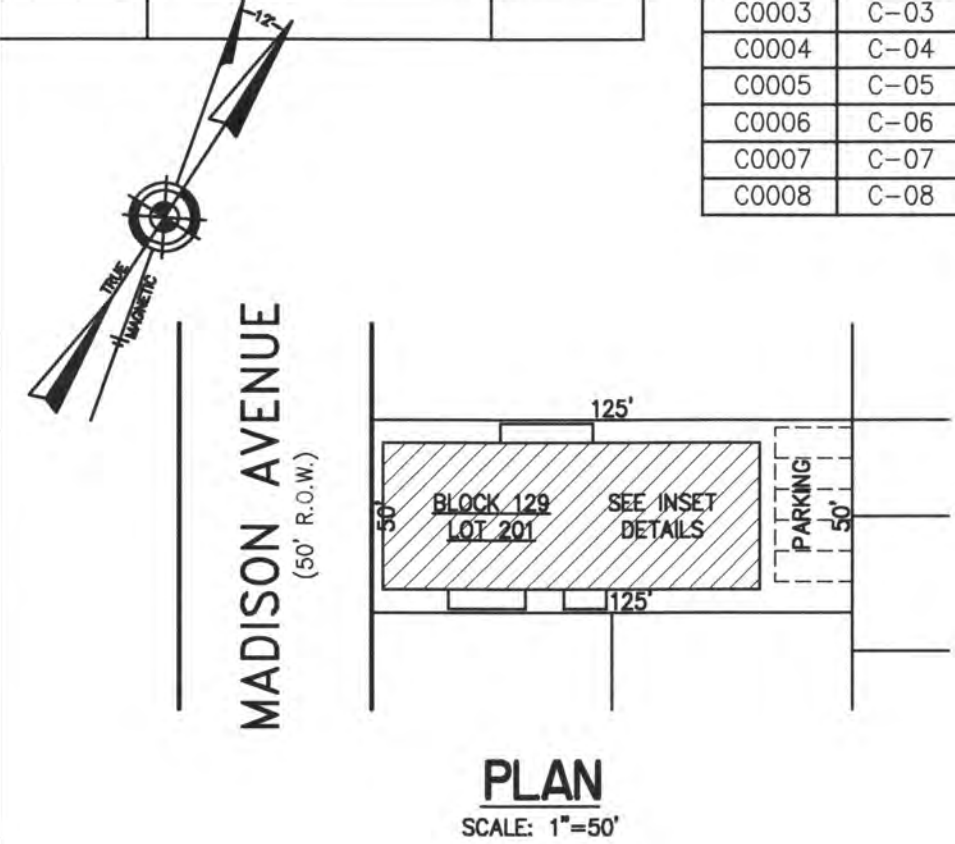

**BLOCK 129, LOT 201
MANHATTAN CONDOMINIUM
21 SOUTH MADISON AVENUE
INSET "LL"**

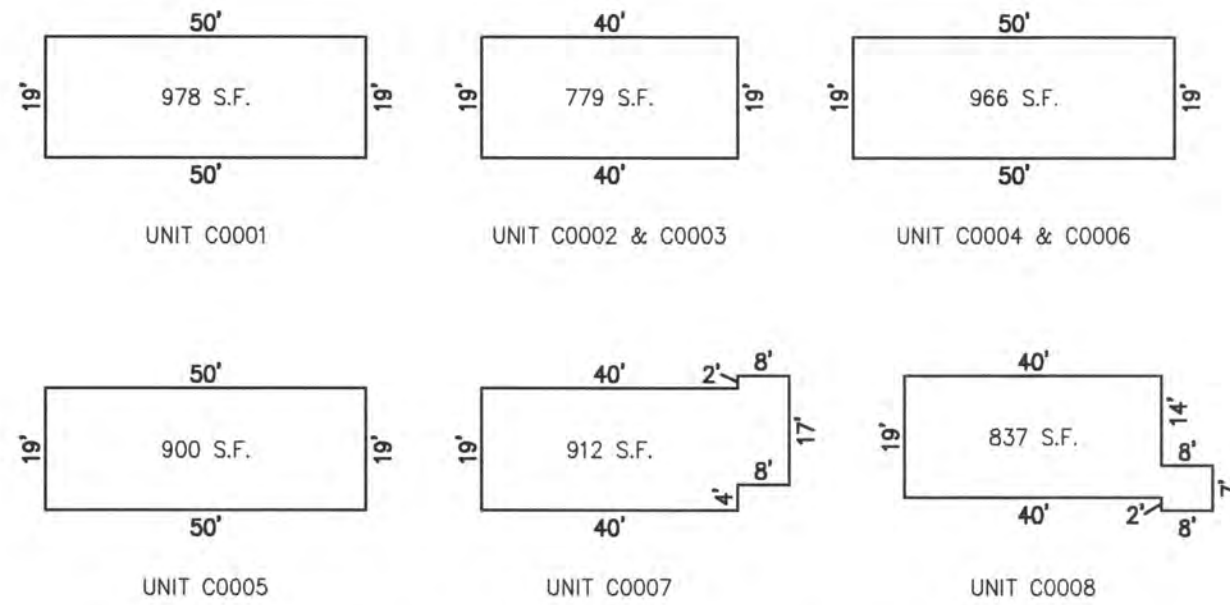
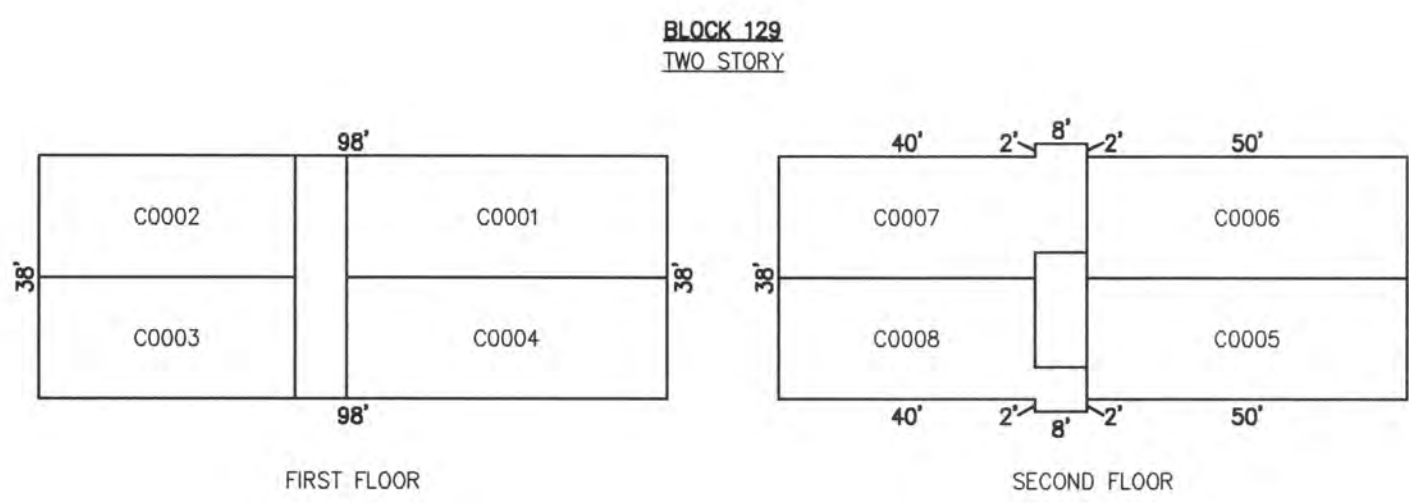

**DETAILS
SCALE: 1"=30'**

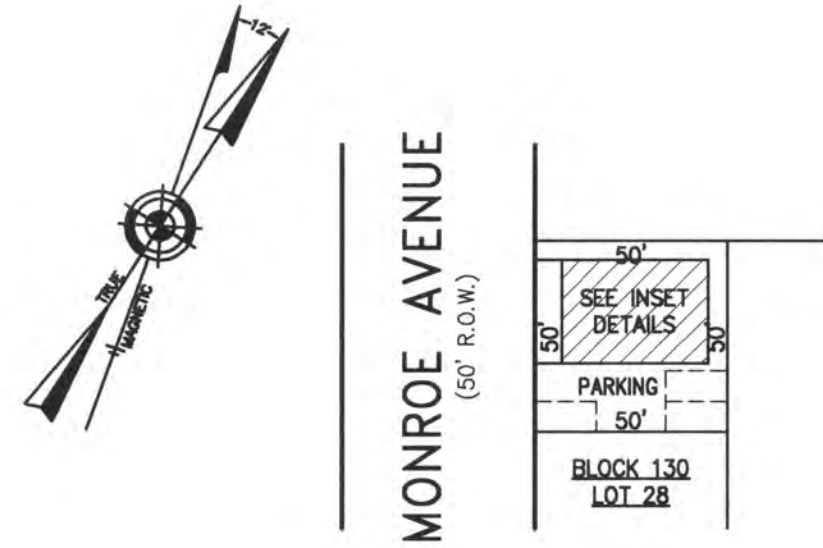

**BLOCK 130, LOT 28
23 SOUTH CONDOMINIUM
23 SOUTH MONROE AVENUE
INSET "MM"**

UNIT NO.	LOT NO.
28A	C-28.01
28B	C-28.02
28C	C-28.03

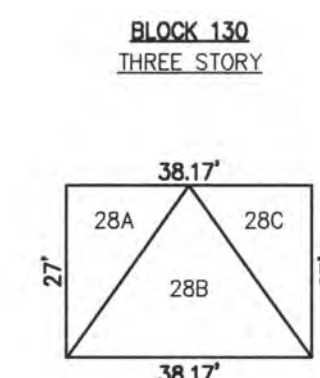

UNIT 28A UNIT 28B & 28C
1026 S.F. 1082 S.F.

**DETAILS
SCALE: 1"=30'**

NOTE: DIMENSIONS AND SQUARE FOOTAGE ARE TYPICAL FOR SIMILAR UNITS

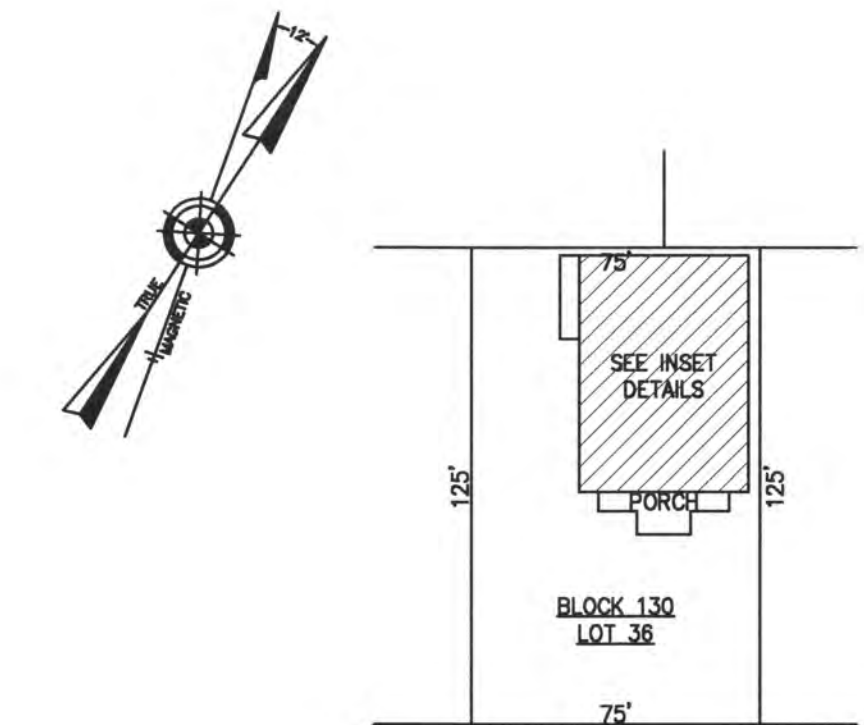

**BLOCK 130, LOT 36
PRESIDENTIAL CONDOMINIUM
9609-13 PACIFIC AVENUE
INSET "OO"**

**PLAN
SCALE: 1"=50'**

UNIT NO.	LOT NO.
C001	C-01
C002	C-02
C003	C-03
C004	C-04
C005	C-05
C006	C-06
C007	C-07
C008	C-08
C009	C-09

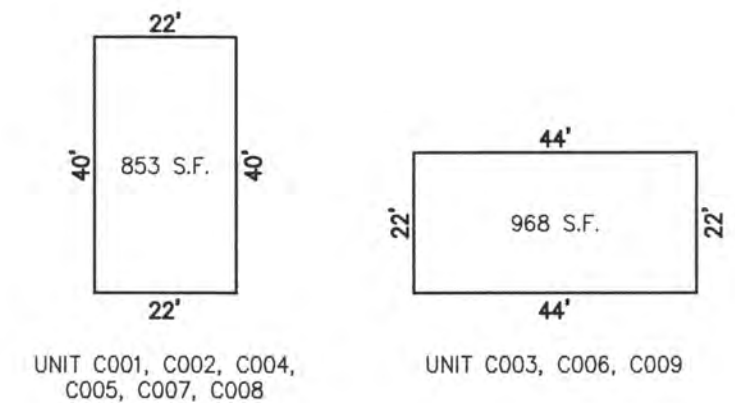
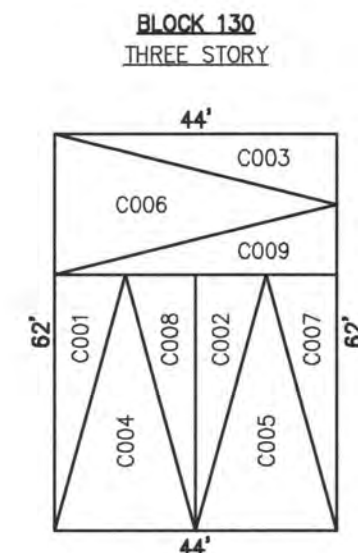

NOTE: 1. DIMENSIONS AND SQUARE FOOTAGE ARE TYPICAL FOR FIRST TO THIRD FLOOR
2. DIMENSIONS AND SQUARE FOOTAGE ARE TYPICAL FOR SIMILAR UNITS

**DETAILS
SCALE: 1"=30'**

**BLOCK 130, LOT 36
PRESIDENTIAL CONDOMINIUM
9609-13 PACIFIC AVENUE
INSET "OO"**



**VENTNOR AVENUE
(COUNTY ROUTE NO. 629)
(80' R.O.W.)**

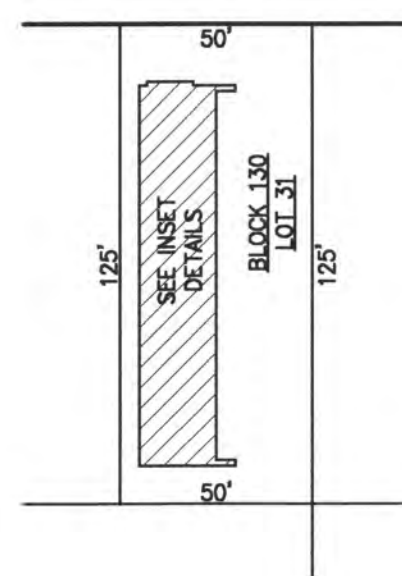

**PLAN
SCALE: 1"=50'**

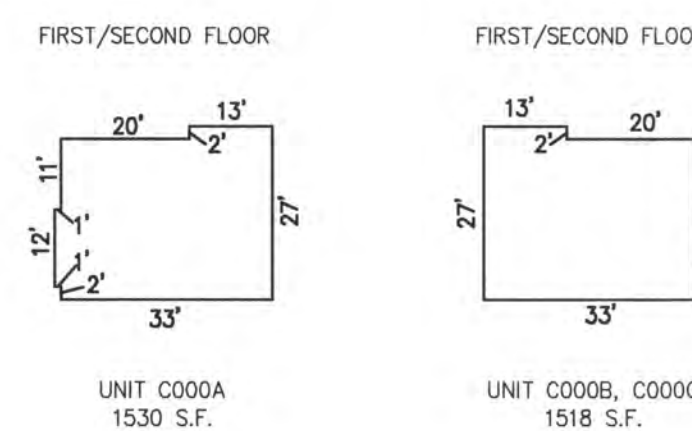
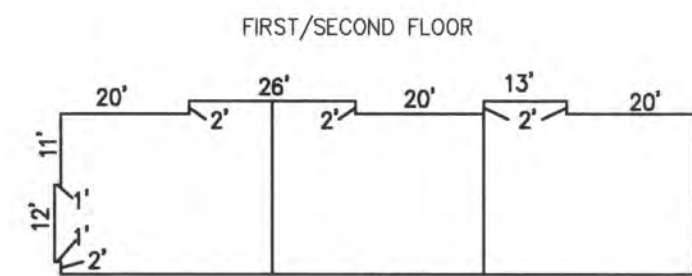
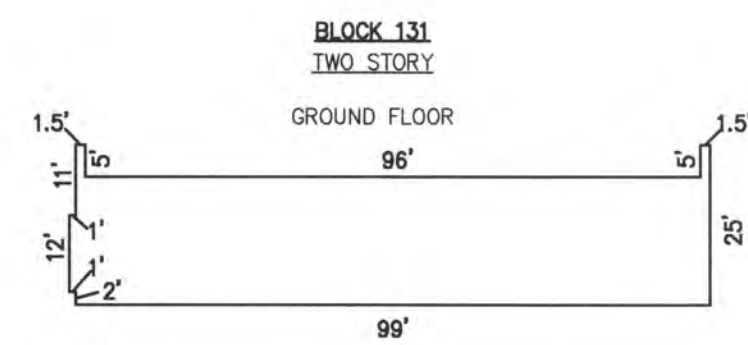

**DETAILS
SCALE: 1"=30'**

**BLOCK 130, LOT 31
9612 VENTNOR CONDOMINIUM
9612 VENTNOR AVENUE
INSET "NN"**

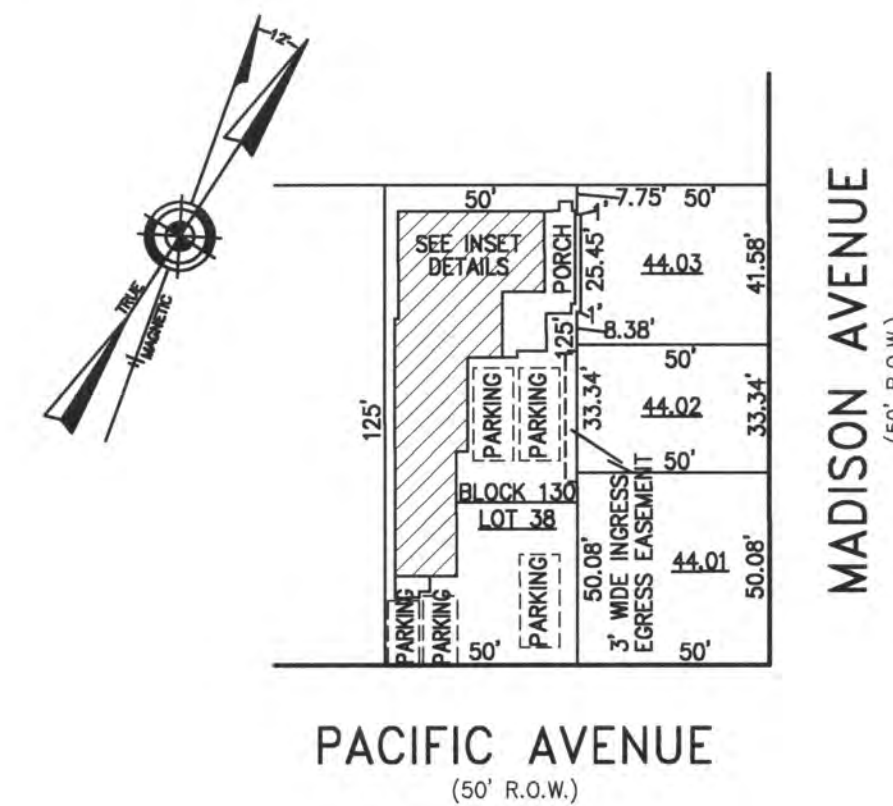

**BLOCK 130, LOT 38
9607 PACIFIC CONDOMINIUM
9607 PACIFIC AVENUE
INSET "PP"**

**PLAN
SCALE: 1"=50'**

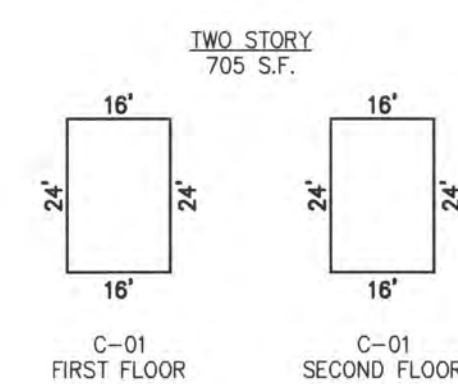

**DETAILS
SCALE: 1"=30'**

**BLOCK 130, LOT 38
9607 PACIFIC CONDOMINIUM
9607 PACIFIC AVENUE
INSET "PP"**

CONDOMINIUM DETAILS AND DIMENSIONS
BLOCK 129, LOT 201
BLOCK 130, LOT 28
BLOCK 130, LOT 31
BLOCK 130, LOT 36
BLOCK 130, LOT 38
SEE PLATE 4

"THIS TAX MAP PLATE HAS BEEN DIGITALLY DRAWN USING COMPUTER-AIDED DRAFTING/DESIGN (CADD) & COORDINATE GEOMETRY (COGO). IT IS BASED ON THE ORIGINAL DIGITALLY DRAWN TAX MAP PLATE BEARING THE OFFICIAL NEW JERSEY DIVISION TAXATION APPROVAL STAMP WITH APPROVAL DATE 6-3-2005 SERIAL NUMBER 846 AND SIGNATURES OF SIGNERS' THOMAS J. REILLY, CHIEF, LOCAL PROPERTY, FIELD ASSISTANCE. SANTO C. DIDONATO, SUPERVISING FIELD REPRESENTATIVE. THE ORIGINAL DIGITALLY DRAWN TAX MAP PLATE WITH THE OFFICIAL APPROVAL STAMP IS ON FILE WITH REMINGTON, VERNICK & WALBERG ENGINEERS."

**TAX MAP
CITY OF MARGATE**

ATLANTIC COUNTY NEW JERSEY
SCALE: AS NOTED DATE: 1-30-2004

CRAIG F. REMINGTON LAND SURVEYOR LIC. NO. 23924



REMINGTON, VERNICK & WALBERG ENGINEERS
24 GA 28048700
845 N. MAIN STREET, PLEASANTVILLE, NJ 08232
(609) 645-7100, FAX (609) 645-7076
WEB SITE ADDRESS: WWW.RVW.COM