

REVISIONS			
NO.	DATE	DESCRIPTION	BY

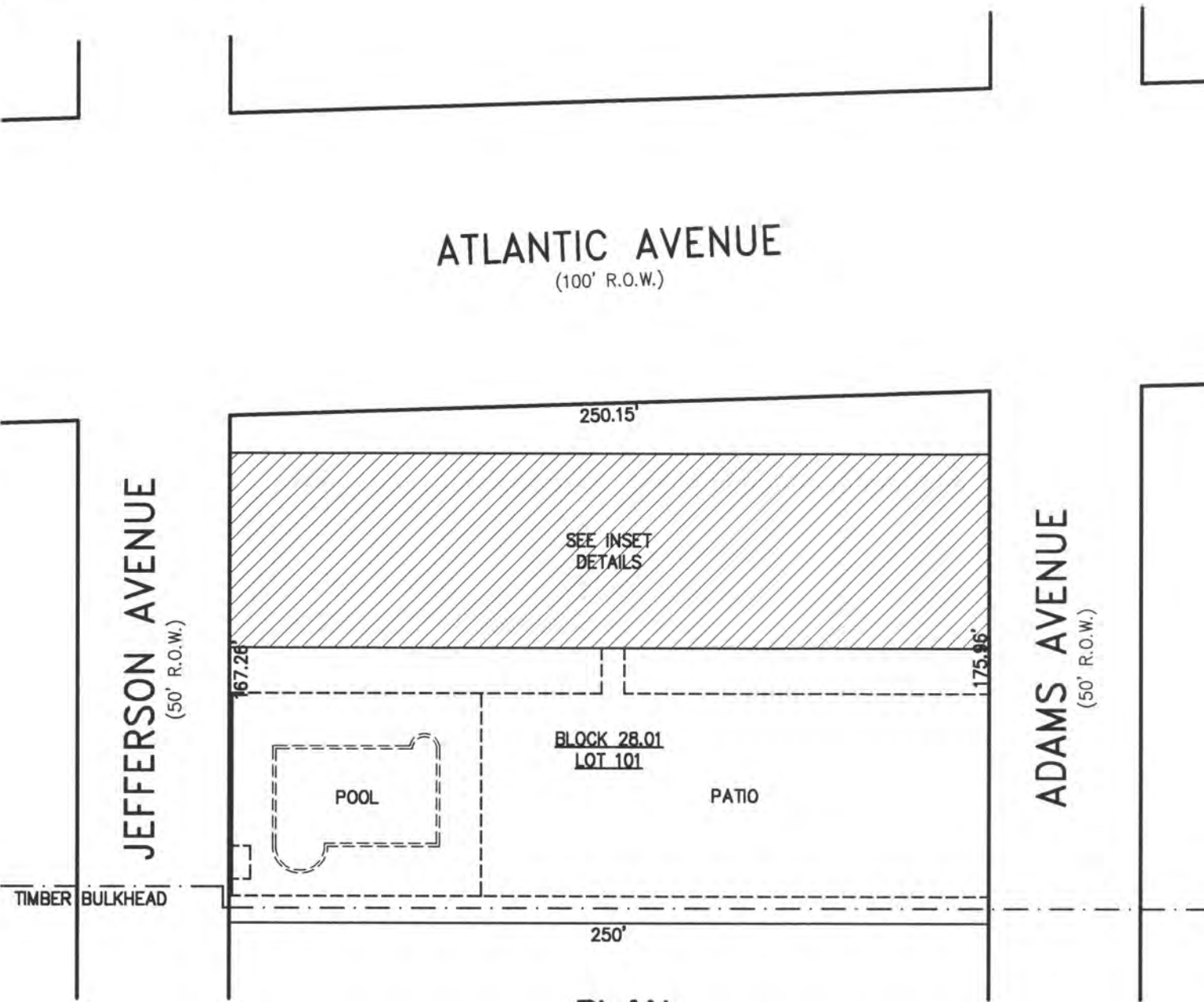

PLAN
SCALE: 1"=50'

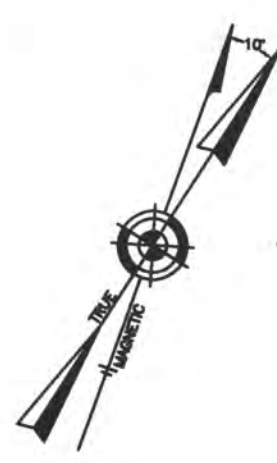
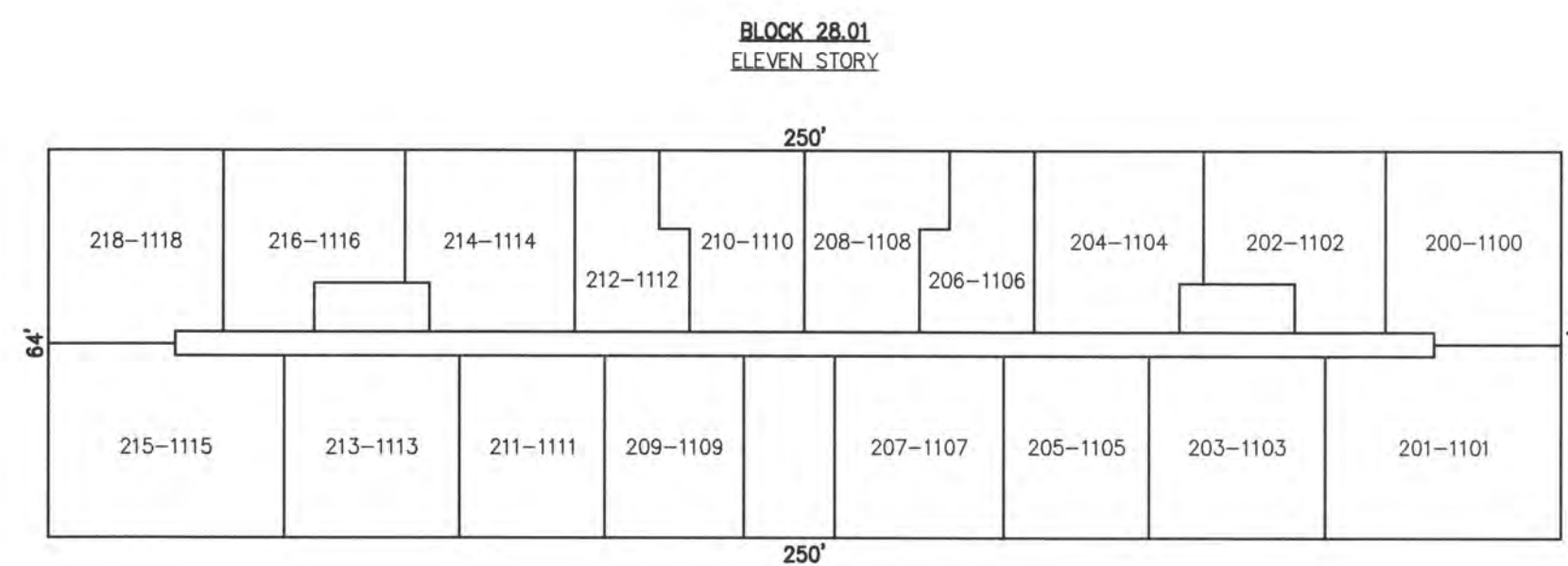

SECOND FLOOR - ELEVENTH FLOOR

DETAILS
SCALE: 1"=30'

UNIT NO.	LOT NO.	UNIT NO.	LOT NO.	UNIT NO.	LOT NO.	UNIT NO.	LOT NO.	UNIT NO.	LOT NO.
200	C-101.200	404	C-101.404	608	C-101.608	812	C-101.812	1016	C-101.1016
201	C-101.201	405	C-101.405	609	C-101.609	813	C-101.813	1018	C-101.1018
202	C-101.202	406	C-101.406	610	C-101.610	814	C-101.814	1100	C-101.1100
203	C-101.203	407	C-101.407	611	C-101.611	815	C-101.815	1101	C-101.1101
204	C-101.204	408	C-101.408	612	C-101.612	816	C-101.816	1102	C-101.1102
205	C-101.205	409	C-101.409	613	C-101.613	818	C-101.818	1103	C-101.1103
206	C-101.206	410	C-101.410	614	C-101.614	900	C-101.900	1104	C-101.1104
207	C-101.207	411	C-101.411	615	C-101.615	901	C-101.901	1105	C-101.1105
208	C-101.208	412	C-101.412	616	C-101.616	902	C-101.902	1106	C-101.1106
209	C-101.209	413	C-101.413	618	C-101.618	903	C-101.903	1107	C-101.1107
210	C-101.210	414	C-101.414	700	C-101.700	904	C-101.904	1108	C-101.1108
211	C-101.211	415	C-101.415	701	C-101.701	905	C-101.905	1109	C-101.1109
212	C-101.212	416	C-101.416	702	C-101.702	906	C-101.906	1110	C-101.1110
213	C-101.213	418	C-101.418	703	C-101.703	907	C-101.907	1111	C-101.1111
214	C-101.214	500	C-101.500	704	C-101.704	908	C-101.908	1112	C-101.1112
215	C-101.215	501	C-101.501	705	C-101.705	909	C-101.909	1113	C-101.1113
216	C-101.216	502	C-101.502	706	C-101.706	910	C-101.910	1114	C-101.1114
218	C-101.218	503	C-101.503	707	C-101.707	911	C-101.911	1115	C-101.1115
300	C-101.300	504	C-101.504	708	C-101.708	912	C-101.912	1116	C-101.1116
301	C-101.301	505	C-101.505	709	C-101.709	913	C-101.913	1118	C-101.1118
302	C-101.302	506	C-101.506	710	C-101.710	914	C-101.914	-	-
303	C-101.303	507	C-101.507	711	C-101.711	915	C-101.915	-	-
304	C-101.304	508	C-101.508	712	C-101.712	916	C-101.916	-	-
305	C-101.305	509	C-101.509	713	C-101.713	918	C-101.918	-	-
306	C-101.306	510	C-101.510	714	C-101.714	1000	C-101.1000	-	-
307	C-101.307	511	C-101.511	715	C-101.715	1001	C-101.1001	-	-
308	C-101.308	512	C-101.512	716	C-101.716	1002	C-101.1002	-	-
309	C-101.309	513	C-101.513	718	C-101.718	1003	C-101.1003	-	-
310	C-101.310	514	C-101.514	800	C-101.800	1004	C-101.1004	-	-
311	C-101.311	515	C-101.515	801	C-101.801	1005	C-101.1005	-	-
312	C-101.312	516	C-101.516	802	C-101.802	1006	C-101.1006	-	-
313	C-101.313	518	C-101.518	803	C-101.803	1007	C-101.1007	-	-
314	C-101.314	600	C-101.600	804	C-101.804	1008	C-101.1008	-	-
315	C-101.315	601	C-101.601	805	C-101.805	1009	C-101.1009	-	-
316	C-101.316	602	C-101.602	806	C-101.806	1010	C-101.1010	-	-
318	C-101.318	603	C-101.603	807	C-101.807	1011	C-101.1011	-	-
400	C-101.400	604	C-101.604	808	C-101.808	1012	C-101.1012	-	-
401	C-101.401	605	C-101.605	809	C-101.809	1013	C-101.1013	-	-
402	C-101.402	606	C-101.606	810	C-101.810	1014	C-101.1014	-	-
403	C-101.403	607	C-101.607	811	C-101.811	1015	C-101.1015	-	-

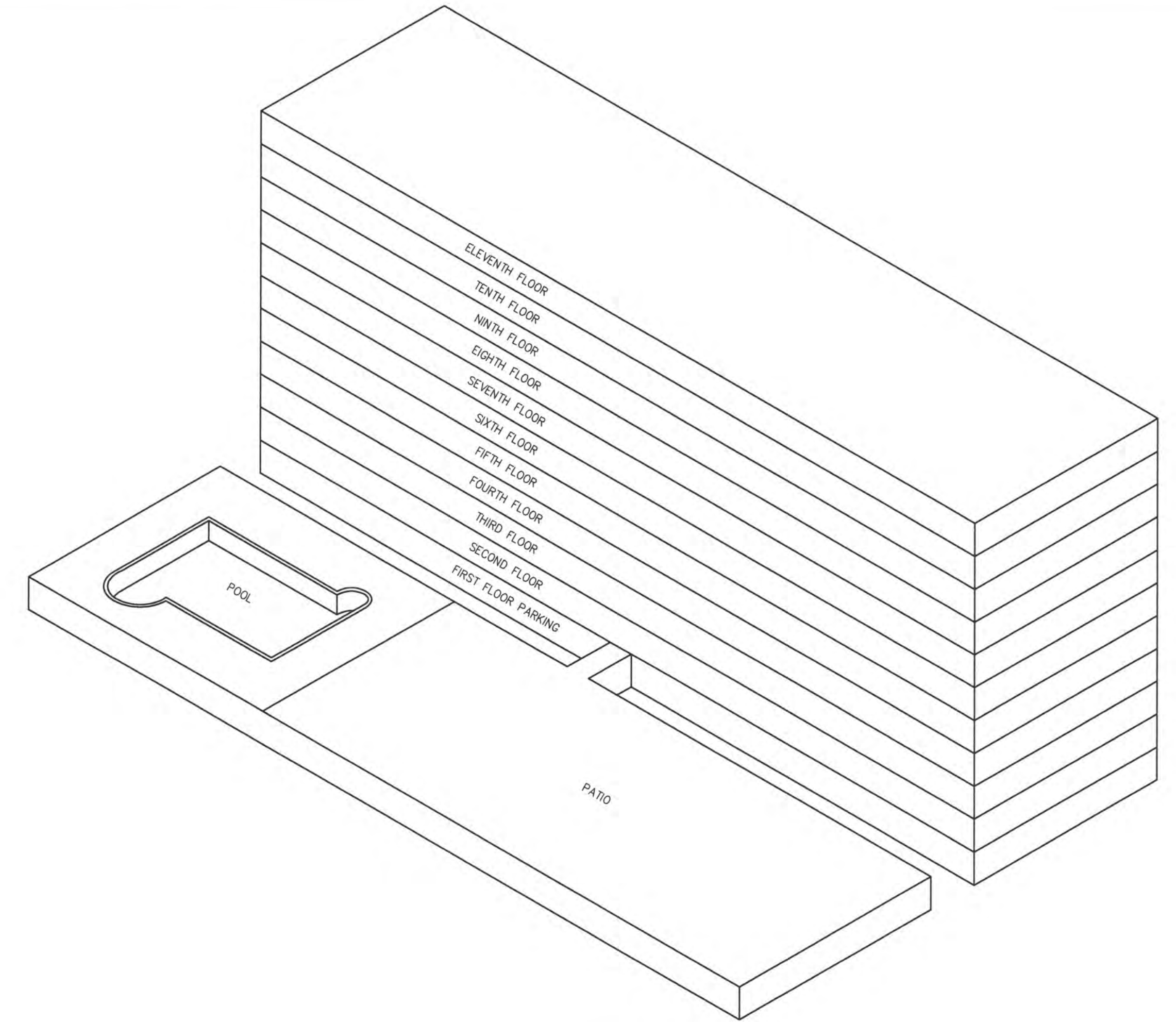

DETAIL
SCALE: 1"=30'

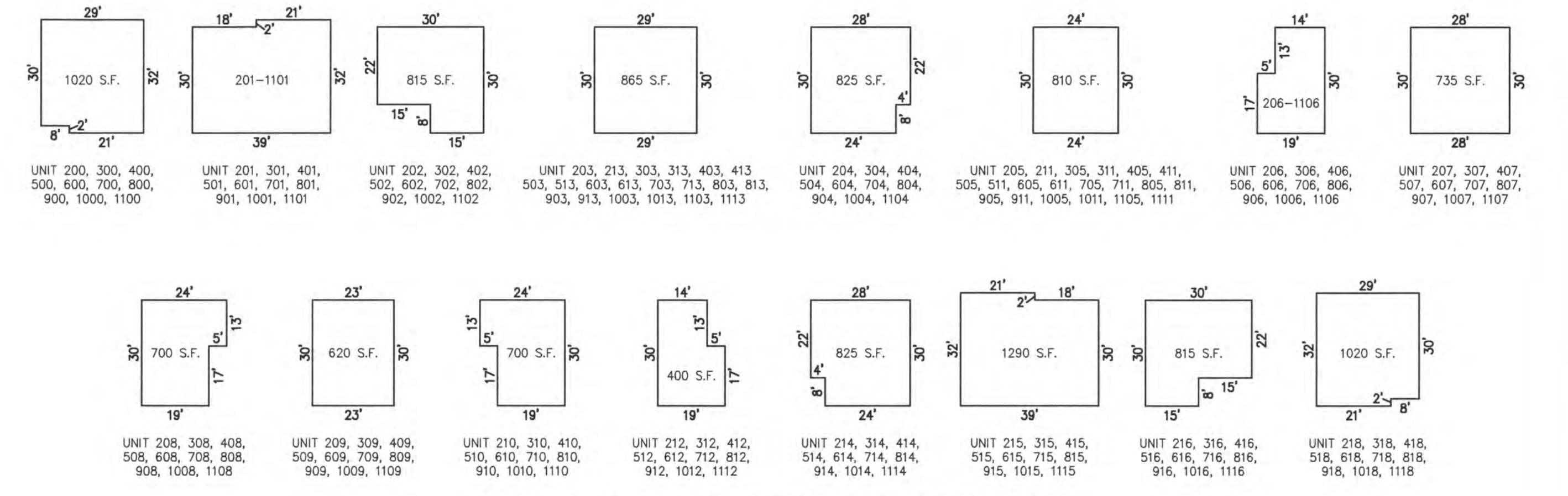

NOTE: 1. DIMENSIONS AND SQUARE FOOTAGE ARE TYPICAL FOR SECOND TO ELEVENTH FLOOR.
2. DIMENSIONS AND SQUARE FOOTAGE ARE TYPICAL FOR SIMILAR UNITS.

DETAILS
SCALE: 1"=30'

BLOCK 28.01, LOT 101
MARGATE TOWERS CONDOMINIUM
9400 ATLANTIC AVENUE
INSET "M"

CONDOMINIUM DETAILS AND DIMENSIONS
BLOCK 28.01, LOT 101
SEE PLATE 23

"THIS TAX MAP PLATE HAS BEEN DIGITALLY DRAWN USING COMPUTER-AIDED DRAFTING/DESIGN (CADD) & COORDINATE GEOMETRY (COGO). IT IS BASED ON THE ORIGINAL DIGITALLY DRAWN TAX MAP PLATE BEARING THE OFFICIAL NEW JERSEY DIVISION TAXATION APPROVAL STAMP WITH APPROVAL DATE 6-3-2005 SERIAL NUMBER 846 AND SIGNATURES OF SIGNERS THOMAS J. REILLY, CHIEF, LOCAL PROPERTY, FIELD ASSISTANCE, SANTO C. DIDONATO, SUPERVISING FIELD REPRESENTATIVE. THE ORIGINAL DIGITALLY DRAWN TAX MAP PLATE WITH THE OFFICIAL APPROVAL STAMP IS ON FILE WITH REMINGTON, VERNICK & WALBERG ENGINEERS."

RV & W
REMINGTON, VERNICK & WALBERG ENGINEERS
24 GA 28048700
845 N. MAIN STREET, PLEASANTVILLE, N.J. 08232
(609) 645-700, FAX (609) 645-7076
WEB SITE ADDRESS: WWW.RVW.COM

TAX MAP
CITY OF MARGATE
ATLANTIC COUNTY NEW JERSEY
SCALE: AS NOTED DATE: 1-30-2004
CRAIG F. REMINGTON LAND SURVEYOR LIC. NO. 23924